



Operating Manual

BioSealer[®] TC



Technical Safety Information for the User

This description contains the necessary information for the designated use of the product described herein. It is intended for technically qualified personnel.

Qualified personnel are persons who, because of their education, experience and training as well as their knowledge of relevant standards, specifications, accident-prevention regulations and operating conditions, have been authorized by persons responsible for system safety to execute the necessary activities, and can recognize and avoid possible dangers in such activities.

Change index

Doc new version	Change
00.000.000	Document created (copied by BWTC) on 24.04.2015
00.001.000	First draft for the release of prototypes
00.001.001	Draft adapted for prototype 2, beta site tests
01.000.000	TÜV Süd certification
07.06.2019	Release for Marcom

Contents

1 About this Document	4	7.3 Web browser.....	30
1.1 Symbols Used.....	4	7.3.1 Connecting.....	30
1.1.1 Other Symbols.....	4	7.3.2 Menu tree.....	30
2 Hazard Information	5	7.3.3 Operating elements.....	31
3 General Information	7	7.3.4 Browser appearance.....	31
3.1 Disclaimer of liability.....	7	7.3.5 General parameters.....	32
4 Introduction	8	7.3.6 User Login -out.....	33
4.1 Characteristics.....	8	7.3.7 User Management.....	34
4.2 Safety.....	8	7.3.8 Info.....	34
4.3 Limitations.....	8	7.3.9 Log.....	35
4.4 Function.....	9	7.3.10 Date and time.....	35
4.5 Blocked device.....	9	8 Runs	36
4.6 Cleaning instructions.....	9	8.1 Initialize axes.....	36
4.7 Decontamination.....	10	8.2 Sealing.....	36
4.8 Carrying Information.....	11	8.3 Power failure.....	36
5 Start-up	12	8.4 Temperature validation.....	37
5.1 Delivery kit.....	12	8.5 Service position.....	37
5.2 Familiarise yourself with the equipment.....	12	9 Log	38
5.3 Assembly.....	12	9.1 Seal Log Screen.....	39
5.4 Log in.....	13	10 User groups and user interfaces	40
5.5 Maintenance.....	13	11 Operating problems	41
5.6 Change settings.....	13	11.1 Switch off the device.....	41
5.7 Initialize axes.....	13	11.2 Foreign objects in the device.....	41
6 Sealing process	14	11.3 Incorrect tubing inserted.....	41
6.1 Insert tubing and close cover.....	14	11.4 Memory card.....	41
6.2 Compression phase.....	15	11.5 Lost password.....	41
6.3 Set clamps.....	16	11.6 Manual cover opening.....	42
6.4 Sealing process.....	16	12 Error reports and Warning messages	43
6.5 Seal log screen (optional).....	17	13 Disposal	44
6.6 Remove tubing.....	17	13.1 Information on Decontamination.....	44
6.7 Sealing visual inspection.....	18	13.2 Disassembly.....	44
6.8 Clamps (removing).....	18	13.3 Disposing of Device and Parts.....	45
7 User interface	19	13.3.1 Information on Disposal.....	45
7.1 Mutual exclusion.....	19	13.3.2 Disposal.....	45
7.2 Touchscreen.....	20	14 Technical data	46
7.2.1 Menu tree.....	20	14.1 Device.....	46
7.2.2 Summary of symbols.....	22	14.2 Power supply.....	46
7.2.3 Operating elements.....	23	14.3 Dimensions.....	47
7.2.4 User Login Logout.....	24	15 Appendix	48
7.2.5 Date and time.....	25	15.1 Copyright.....	48
7.2.6 Language.....	25	15.2 Technical contact.....	48
7.2.7 Tubing.....	26		
7.2.8 Network Parameters Reset.....	26		
7.2.9 User administration.....	27		
7.2.10 Log.....	28		
7.2.11 Info.....	29		

1 About this Document

This document is intended for users of BioSealer® TC from the user group "Supervisor" and "Operator".

1.1 Symbols Used

WARNING

Denotes a danger with risk that death or severe injury may result if it is not avoided.

CAUTION

Denotes a danger with risk that moderate or minor injury may result if it is not avoided.

NOTICE

Denotes a danger that can result in property damage if it is not avoided.

1.1.1 Other Symbols

- ▶ Required action: Describes actions which must be carried out.
- ▷ Result: Describes the result of the activities carried out.

- ✓ Ok, the way it must be. The BioSealer® TC may be used like this.
- ✗ Not ok, must be changed | fixed! The BioSealer® TC must not be used like this!

2 Hazard Information

The following information is for the personal safety of operating personnel as well as the safety of the described product.



Hand injury warning

Never grab hold of anything inside openings during operation. Noncompliance can lead to serious injury.



Warning of hot surface

Inside the device, the surface can be hot and cause burns | injury. These surfaces must not be touched. The device must first be cooled before maintenance | cleaning.



Disconnect power

To disconnect the BioSealer® TC from power, turn off the device and unplug the power plug from the cable of the BioSealer® TC. Always keep the access to the power plug free!



Electrostatic sensitive devices (ESD)

Ground straps, table mats and tools with conducting grips are used to ground people, to achieve equipotential welding and to prevent electrostatic discharge. This is always a requisite measure if electronics or electronic components are handled or mounted.

WARNING

- ▶ Ground conductor connections must function perfectly (power supply connection).
- ▶ The device is not intended for use in | with explosive atmospheres.
- ▶ Not following the manual instructions of the manufacturer may lead in to unreliability, hazardous situations and disturbances of safety.

CAUTION

- ▶ Disconnect the device from the power source before cleaning. Never open up the device!
- ▶ The device is intended to use for technical qualified personnel only!

NOTICE

- ▶ Follow the accident-prevention and safety regulations relating to the specific application.
- ▶ During the sealing process tubing must not be under pressure. Follow carefully the instructions on the display to avoid any issues due to overpressure. Read the relevant chapter „6 Sealing process“, page 14.
- ▶ An interruption during the sealing process can lead to an issue and must be avoided. The device will try to limit the damage. Be sure to follow the operating instructions to the letter. Read the relevant chapter „8.3 Power failure“, page 36.
- ▶ In the event of an accident, the device must be cleaned and examined by an authorised specialist.
- ▶ The device must be decontaminated before being sent to suppliers or manufacturers.

NOTICE

- ▶ As the BioSealer® TC is intended to use as a handheld device, the operator must use safety shoes to prevent harm from a falling device.
 - ▶ Be aware that microscopic or macroscopic particles | fluids of the tubing inner may be released into the environment during the sealing process or after separation.
 - ▶ Before start-up, check whether the nominal voltage of the power supply matches the local mains voltage.
 - ▶ The device was developed for laboratory use and must be protected from every type of fluid or vapour.
 - ▶ The device can be operated between +5°C and +40°C. The sealing parameters are qualified for room temperature operation only.
 - ▶ Optimal relative humidity is 60%.
 - ▶ The device is programmed with standard parameter sets for sealing TuFlux® TPE, C-Flex® 374, AdvantaFlex®, PharMed® BPT and SaniPure™ BDF™. These parameter sets have been validated at ambient temperature.
 - ▶ The degree of protection is IP20.
 - ▶ Make sure that the device is not switched off during the sealing process.
 - ▶ To increase process reliability ensure that there is an uninterrupted power supply (UPS).
 - ▶ Use only tested control cables and accessories provided by the manufacturer.
 - ▶ Fuses may only be exchanged by a service technician.
 - ▶ The device has an Ethernet connection. Only skilled personnel may connect the device to a network.
 - ▶ Only shielded Ethernet cables may be used.
 - ▶ Only skilled personnel may configure the device for connection to a network.
 - ▶ It is recommended to operate the device via the touch screen.
 - ▶ The device contains electric drives which can be blocked | destroyed by foreign substances. Make sure that no foreign substances reach the interior of the device.
 - ▶ After using the BioSealer® TC, you should always log out. Otherwise another user is able to manipulate the device with your account.
 - ▶ The auto login is used to work more efficiently with the BioSealer® TC. The auto login can only be activated for one user. This user will be logged in automatically without entering any username and password after each restart or after changing the user interface.
 - ▶ A user of the Supervisor group should **not** use the auto login because of security reasons, otherwise any user is able to take critical changes on the BioSealer® TC under the Supervisor account.
 - ▶ Extension cord between power supply and BioSealer® TC must not be longer than 3 meters.
-

3 General Information

Please read this operating manual carefully. It allows you to start up and operate the device safely and successfully.

3.1 Disclaimer of liability

Sartorius Stedim Biotech SA cannot accept any liability for errors and damages that occur caused by improper handling and by improper use of the device. Improper handling arises if the operating instructions, in particular the instructions for start-up, are not followed. Device returns must be made only in the original packaging or in accordance with safe packaging. No liability is assumed for transport damage. The BioSealer® TC is intended for industrial use and should not be used for human medical applications. No liability is assumed for errors when connecting the device to a network.

The system is intended for the purpose described above only. Any other use or change of the device without written agreement with the manufacturer is considered to be improper. The manufacturer is not liable for any resulting damage. The risk is borne solely by the operator.

The manufacturer assumes no liability for any damage or consequential damage to the device or the application resulting from an accident.

4 Introduction

The inserted dry or liquid filled tubing is compressed between two heating elements. The heat and the compression force generate a homogeneous sealing of the tubing section. The resulting sealing can be cut through the embedded guideline using scissors.

The BioSealer[®] TC device is capable of sealing TPE tubing, either gamma-irradiated or autoclaved, from 1/4" up to 1" OD. Sealing parameters for all tubing dimensions and materials are pre-installed on the system and simple to select via touch screen. Disconnections can be performed on dry, wet or liquid filled tubing. Due to its weight and small dimensions the unit is portable and can be easily used in a variety of locations.

4.1 Characteristics

Feature	Benefit
Sealing of dry or liquid filled tubing from 1/4" to 1" OD without the need for accessories	One device to seal all tubing sizes under different process conditions
Larger sealing area with cutting guide	Increased sealing robustness and safer disconnection
Fully automated portable device without accessory required	Reusable and easy to use
Standard programs for TPE tubings	Ready to use for TuFlux [®] TPE, C-Flex [®] 374, AdvantaFlex [®] , SaniPure [™] BDFM (except 3/4" x 1") and PharMed [®] BPT
New design	<ul style="list-style-type: none"> – Ergonomic – Operator friendly – Easy to use

4.2 Safety

Since drives are moved with strong forces, the cover or finger protections must not be opened during a run in order to avoid injuries. The cover is automatically released by the device as soon as the user's safety is ensured. Use only tubing which is compatible with the device.

▶ **⚠ WARNING** If any parts are broken, do not continue to use the device!

4.3 Limitations

The sealings performed with the BioSealer[®] TC guarantee adequate quality and strength for the transfer. Ultimately, however, it is the responsibility of the end user to verify and validate the device for its suitability. Under no circumstances may data from this operation manual be used as a reference for the manufacture of a clinical product at an official location without the written permission of the manufacturer. The BioSealer[®] TC is designed for industrial use and may not be used for medical applications. Further restrictions are given in chapter „2 Hazard Information“, page 5. Sealings must be thoroughly tested before use.

4.4 Function

The BioSealer® TC is used for the sterile separation of tubing. For this purpose, tubing is inserted, the cover is closed and a run is initiated with the start button. During the run, the tubing is automatically squeezed and heated. Subsequently, the tubing is cooled, the tubing is released again and the cover is opened. The resulting sealing has now a guideline indicating where it can be separated with a cutting tool. The BioSealer® TC is a fully automatic device and indicates the completion of the sealing when all steps have been completed.

In order to simplify the logging of the sealing data for the user, the BioSealer® TC is equipped with a memory card, which can be used to write the data as required. In addition, the data can be loaded onto a computer using a web browser. See chapter 7.2.10, page 28 and chapter 7.3.9, page 35 for details.

To simplify the temperature validation or to enable it for the customer, a temperature validation kit adapted to the device can be purchased as an accessory for the BioSealer® TC.

4.5 Blocked device

All operating equipment within the BioSealer® TC device is constantly checked for its proper functioning. In addition, each step is monitored during a run. If an operating equipment, e.g. a drive or the heater breaks down, or fails to execute a step during a run, then an error is present. Such an error results in a blocked device. If the device is blocked, all running processes are stopped and a message is issued to the operators. In the English language this message is: "All runs blocked (X)"

- ▶ **NOTICE** A blocked device is present when the following text is displayed: "All runs blocked (X)"

If a run cannot be completed for any reason, this does not necessarily mean that the device is defective. For example, the user may have chosen incorrect tubing.

- ▶ A blocked device does **not** necessarily have to contain a defective component.
- ▶ See chapter „12 Error reports and Warning messages“, page 43 for trouble shooting information.
- ▶  **WARNING** If the device is defective, it must be repaired urgently. In such a case, contact your local service contact.
- ▶ Before you contact your sales representative, describe the error in detail and save the "All" log as described in the chapter „7.2.10 Log“, page 28. Please submit these data together with the error description to your local service contact.

4.6 Cleaning instructions

- ▶ Before cleaning, the cleaning agent must be tested on compatibility with the respective materials.
- ▶ **NOTICE** The BioSealer® TC may not be cleaned with a spray- or steam procedure. Spray- or steam cleaning can cause a reduced life time of single components or lead to damage of single components.
- ▶ The manufacturer disclaims any liability if components are damaged by improper cleaning or in the case of non-observance of the cleaning instructions or when persons are being injured by not observing the proper cleaning instructions.
- ▶ Use service position for better accessibility to the sealing area. See chapter „8.5 Service position“, page 37.

Recommended cleaning agents:

- Ethanol 70% (e.g. Klericide 70/30)
- Sodium hypochlorite 6% (e.g. Klericide-CR)
- Propanol 45%, Isopropanol 25%, Ethanol 4.7% (e.g. Bacillol AF)

Process description:

1. Move the drives to the service position (see chapter „8.5 Service position“, page 37)
2. Immerse a cleaning tissue with a standard cleaning agent.
3. Clean the following areas marked in green. Do not clean red marked areas!

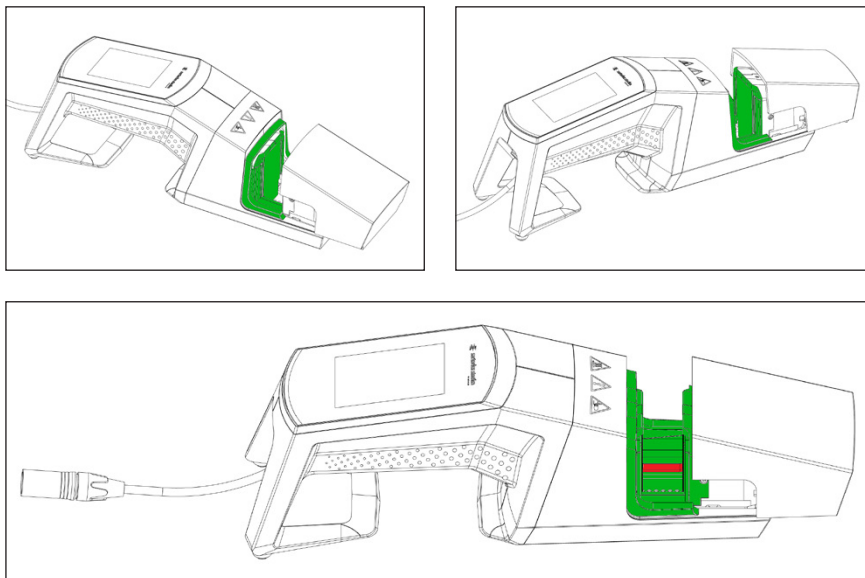

4. Clean the whole case.

It is recommended to clean the device on a weekly base.

4.7 Decontamination

The machine must be decontaminated with either:

- Ethanol 70% (e.g. Klericide 70/30)
- Sodium hypochlorite 6% (e.g. Klericide-CR)
- Propanol 45%, Isopropanol 25%, Ethanol 4.7% (e.g. Bacillol AF)

► **NOTICE** The customer is responsible for correct decontamination!

After correct decontamination, the customer must fill out the "Decontamination form" that the device is free from biological, chemical or radioactive contaminants. This form can be obtained from the local Sartorius Stedim Biotech SA representative.

4.8 Carrying Information

CAUTION

Carry | Hold the BioSealer® TC only the way shown in the picture below.

Not following these instructions may lead in to unreliability, hazardous situations and disturbances of safety.

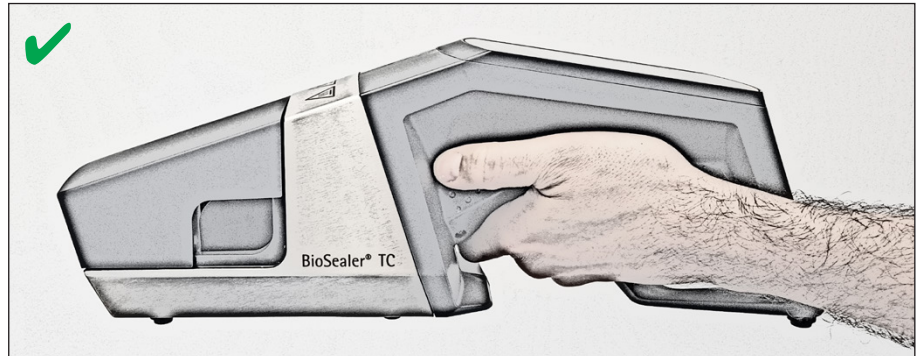

CAUTION

Do **not** carry | hold the BioSealer® TC like shown in the picture below!

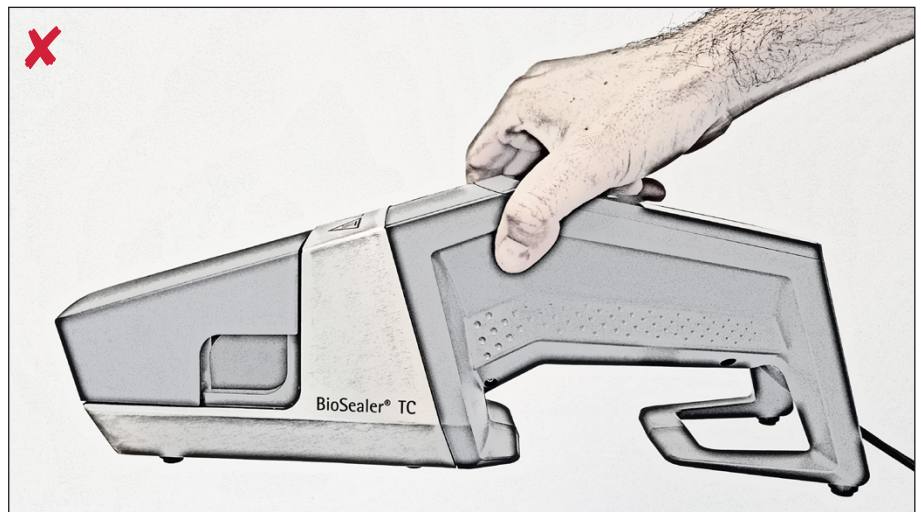

5 Start-up

This chapter is a step by step guide for the start-up of the BioSealer® TC.

5.1 Delivery kit

- BioSealer® TC device
- Power supply
- Power cord
- SD memory card inserted into slot
- Quick starting guide and operating manual
- Product certificate BioSealer® TC
- Calibration certificates

5.2 Familiarise yourself with the equipment

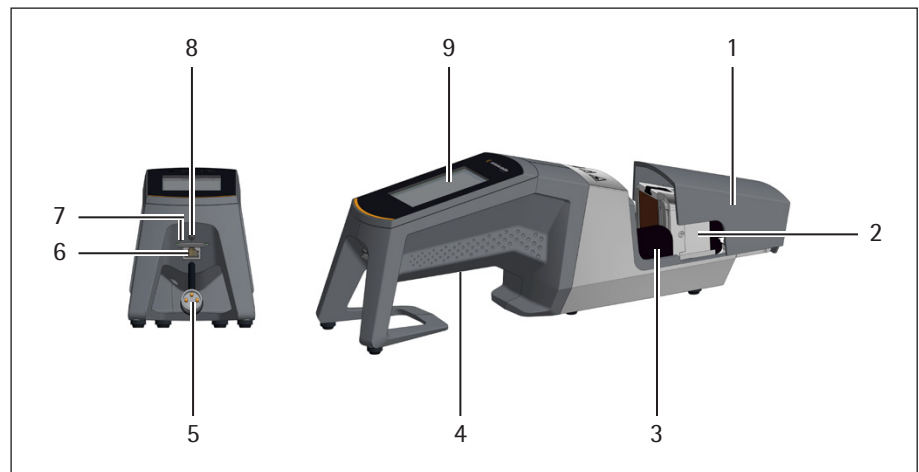

Item	Designation
1	Cover
2	Heating element
3	Finger protection
4	Carrying handle, see chapter „4.8 Carrying Information“, page 11
5	Device cable
6	Ethernet connection
7	Slot SD memory card
8	Power switch
9	Touchscreen

5.3 Assembly

The BioSealer® TC is a portable device. Use a safe surface for installation. Connect the power supply to the appliance inlet and switch the device on. After a brief start-up phase, the device is ready for operation.

5.4 Log in

On delivery, the device is set so that a user with the name "Supervisor" is automatically logged in by the "Supervisor" user group. In this case, the instructions which are necessary to carry out an initialization are displayed on the touch screen.

If no user has the automatic login attribute, the user must login with the user name and password. See chapter „7.2.4 User Login | Logout“, page 24 or chapter „7.3.6 User Login | -out“, page 33.

5.5 Maintenance



Periodic maintenance is required for an optimal working BioSealer® TC. A message on the touch screen indicates if maintenance should be carried out. The criteria for this are internal counters which are linked to the service maintenance schedule of Sartorius.

If a corresponding message appears on the display after logging in, the device must be serviced. This message must be confirmed by the user with the OK key to be able to continue working.

5.6 Change settings

Various settings can be made via the menu, such as: Language, date, time, and tubing type.

- ▶ Read the corresponding chapter „7.2 Touchscreen“, page 20

5.7 Initialize axes



After starting up the device or if tubing with a different outside diameter is selected, an initialisation must necessarily be carried out. Follow the instructions on the touch screen.

- ▶ **NOTICE** Everything must be removed from the squeezing area. The cover is then closed by the user and the device initializes automatically.

6 Sealing process

To perform a sealing, follow the instructions on the touch screen. If the device has not previously been initialised, no sealing can be performed at this status. Proceed as follows:

- ▶ **NOTICE** Verify that tubing is available and the correct tubing is set in the device. See chapter „7.2.7 Tubing“, page 26.
- ▶ **NOTICE** Only use tubing which is dry and cleaned from the outside. Tubing which are externally wet can be damaged.
- ▶ **NOTICE** Tubing must not be under pressure during the sealing process.

6.1 Insert tubing and close cover

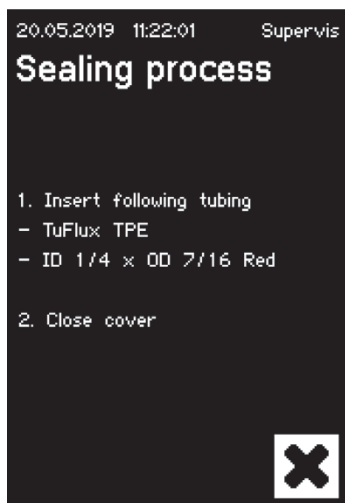

- ▶ **NOTICE** Please insert the tubing according to the following orientations:

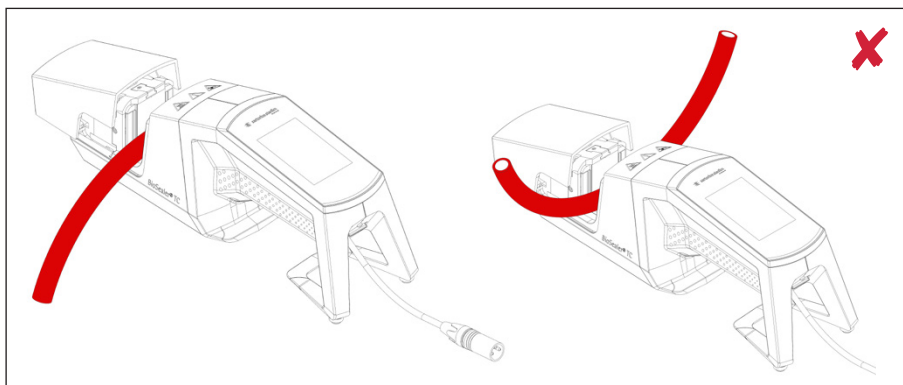
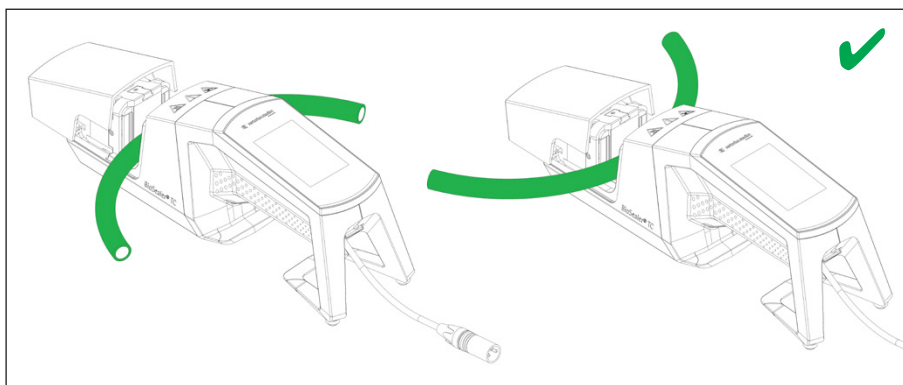



- ▶ **NOTICE** Check on the user interface whether the selected tubing matches the inserted tubing. Internal and external diameters must also be checked. If all details match, press the start button to start the compression phase.

6.2 Compression phase

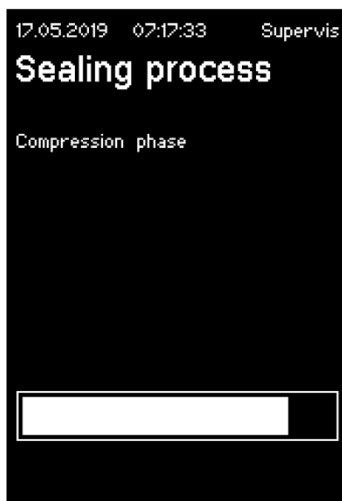

6.3 Set clamps

On both sides of the sealer, the tubing must be clamped.

► **NOTICE** The distance between the clamp and the sealer should be around 4 cm | 1.6 in.

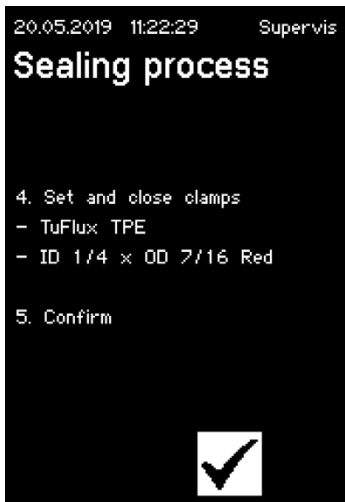

6.4 Sealing process

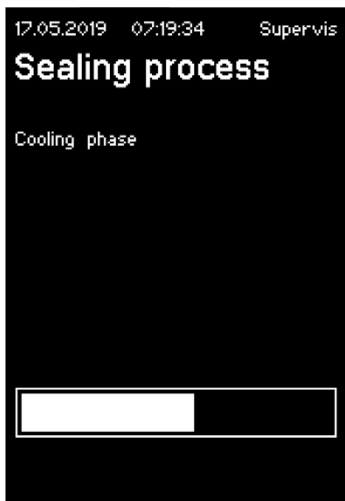

6.5 Seal log screen (optional)

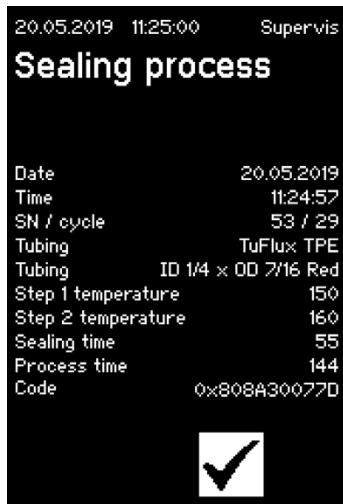

6.6 Remove tubing

Sealing process is completed when the cover opens automatically.

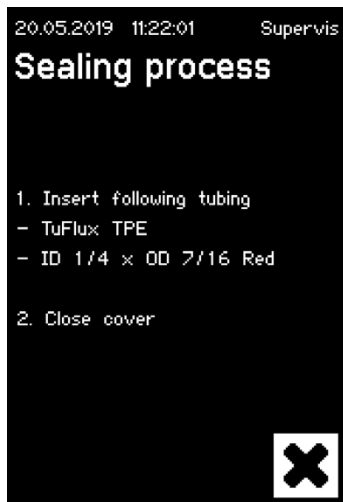

6.7 Sealing visual inspection

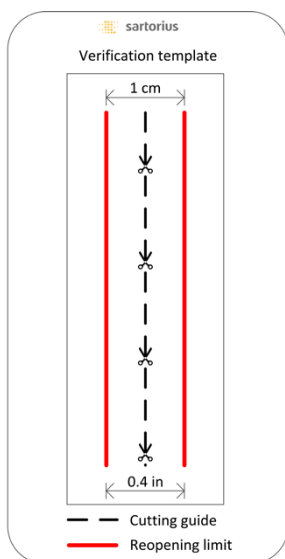

The operator must visually check the sealing. He bears the responsibility. In order to help the operator to assess the sealing quality there is a verification template (see picture left) included into the delivery box that can be used. If the sealing reopening crosses the limit, a new sealing must be performed. If the quality is satisfactory (refer to picture beside), the sealing can be cut following the cutting guideline with rounded scissors.

- **NOTICE** For optimal sealing, allow the tubing to cool down (approx. 5 min) completely before stressing the sealing mechanically.

6.8 Clamps (removing)

If the quality is good and the tubing has been successfully separated, the clamps can now be removed (after 5 min).

- **NOTICE** To ensure a higher safety it is recommended to leave the clamps on the tubing (especially for sizes with OD > 1/2").

7 User interface

The BioSealer® TC is delivered with two user interfaces which partially cover common functionalities. On one hand, the device can be operated via the touch screen integrated in the device, on the other hand via Ethernet over a web browser.

NOTICE

As far as possible, the user should operate the device with the local touch screen. Switching back and forth between touch screen and web browser is not recommended.

The following chapters highlight the differences between the two user interfaces.

7.1 Mutual exclusion

In order to make it clear which user interface has control over the device, rules are implemented:

- ▶ It is only possible to work actively with one user interface at the same time. The other user interface is passive.
- ▶ No user interface is active or passive after a start of the device.
- ▶ Web browser or touch screen are activated as soon as the interface is used e.g. by pressing a key.

Display on a passive touch screen user interface:

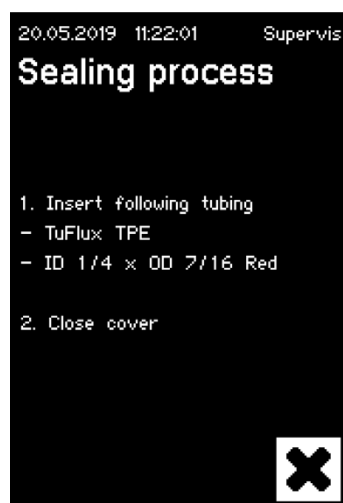

Display on a passive web browser user interface:



Rules for activating | switching a user interface:

- ▶ The touch screen can always be instantly activated by touching it.
- ▶ The web browser can only be activated if no user is logged into the device or after restarting. If you want to activate the web browser user interface, logout on the touchscreen is mandatory.
- ▶ The common factor is that the current user is logged out by switching. If a user has activated automatic login, this user will be logged in, otherwise the login dialogue will appear.

7.2 Touchscreen

The touchscreen is a capacitive touch. The control elements shown can be operated directly.

7.2.1 Menu tree

The following figure shows the menu tree of the touchscreen for the user group "Supervisor".

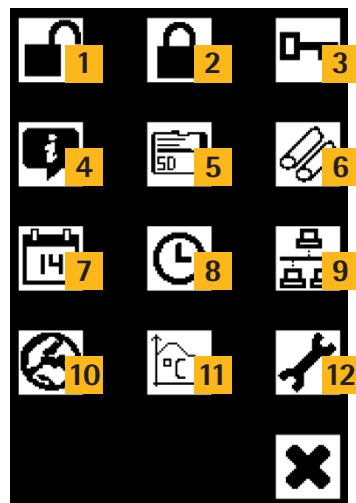

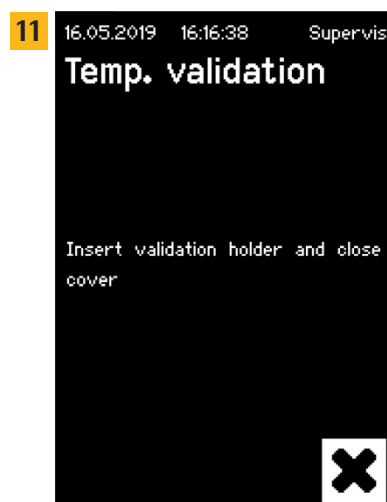
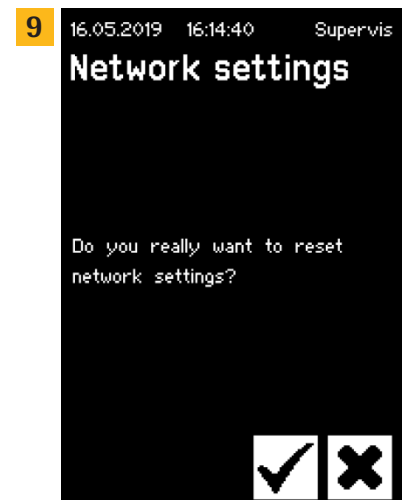
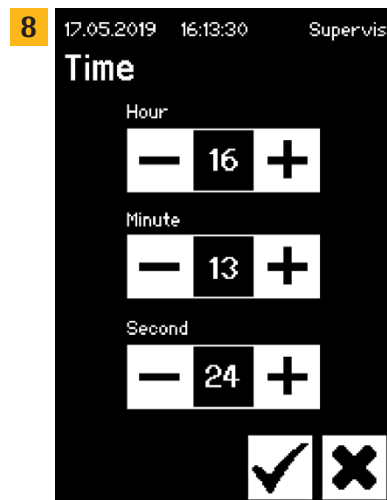
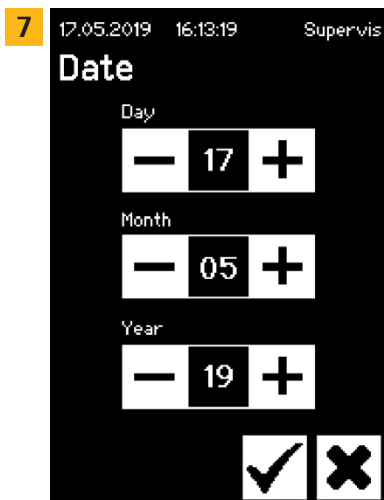
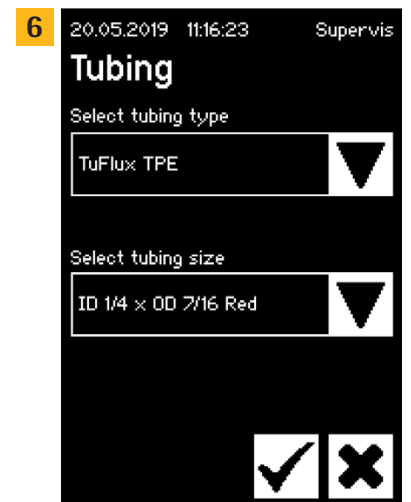
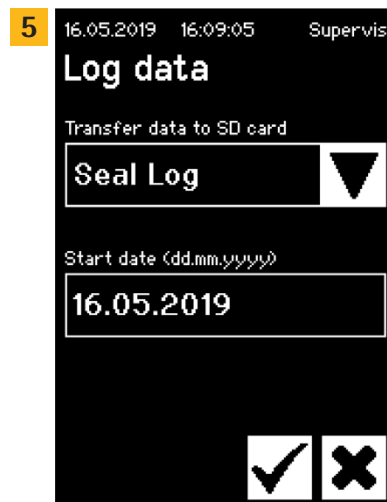
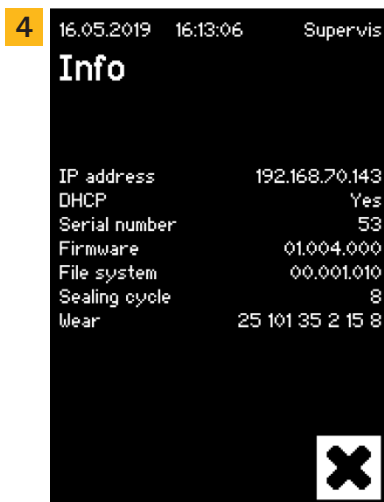

















7.2.2 Summary of symbols

The following tables show the meaning of the symbols displayed on the touch screen.

Common symbols





Symbol	Meaning
	Cancel, the current screen is exited. Changes are discarded.
	OK, changes are accepted and saved by the user or messages are acknowledged.
	Meaning depends on the context. Within a selection box the next object is selected. Within a menu the next screen of the same level is selected.
	Increments a value
	Decrements a value

Menu window

Symbol	Meaning
	User login, see chapter „7.2.4 User Login Logout“, page 24.
	User logout, see chapter „7.2.4 User Login Logout“, page 24.
	General information, see chapter „7.2.11 Info“, page 29.
	Save log data to memory card, see chapter „7.2.10 Log“, page 28.
	User management, see chapter „7.2.9 User administration“, page 27.
	Select the tubing, see chapter „7.2.7 Tubing“, page 26.
	Temperature validate, see chapter „8.4 Temperature validation“, page 37.
	Language of the user interfaces, see chapter „7.2.6 Language“, page 25.
	Set the date, see chapter „7.2.5 Date and time“, page 25.
	Set the time, see chapter „7.2.5 Date and time“, page 25.
	Network parameter reset, see chapter „7.2.8 Network Parameters Reset“, page 26.
	Service position, see chapter „8.5 Service position“, page 37.

7.2.3 Operating elements

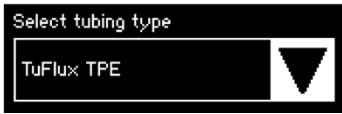
The touch screen has only a few standardized controls which are also common in other user interfaces.

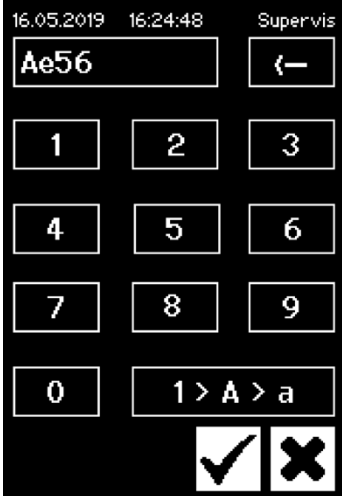
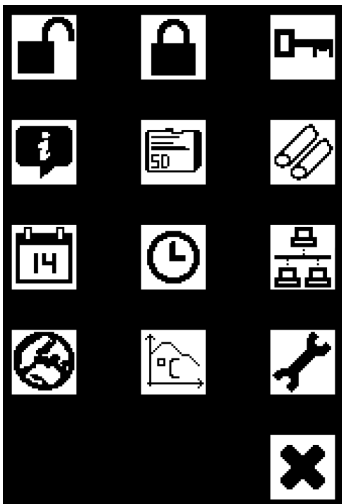
Element	Example	Importance
Button		Start: Start the process
Button		Stop: Terminate the process
Button		Buttons with icon. See chapter „7.2.2 Summary of symbols“, page 22.
Spin box		A "Spin box" offers a selection, which can be selected with the arrow key.
Spin box with input		With a "Spin box with input" an additional input is possible. To do this, touch the selection text. This will open the input window.
Text box		A "text box" is provided for information or required input. A touch within the frame will open the input window.
Input window		With the "input window" an input is possible as with a mobile phone. Alphanumeric entries are possible without special characters but with upper and lower case. The key "1>A>a" is used to switch from numeric input to upper or lower case letter input. The keyboard changes accordingly. Press ← to delete the last character.
Menu		From the "menu" the user can navigate to other functions. The "Cancel" button exits the menu.

7.2.4 User Login | Logout

Login

If no user has the "auto login" attribute, the user must login with the user name and password.

Enter the user name and the corresponding password in the "User login" dialogue. Confirm your entries by pressing the OK button.

- ▶ If a user has the "auto login" attribute, the user logs in automatically after starting up of the device or by changing between the user interfaces (touch screen ◀▶ web browser).



Logout

Explicit logout: After completing the work on the device, the user should logout to ensure that no other user can tamper with the device under false user name.

Automatic logout: If "auto login" is **not** selected, the system automatically logs out after a set time. This time always begins to count when the device has finished a run or when a user interaction has been performed. This time can only be changed via the Web Interface (General Parameters, Auto logout time) and is set up to 10 minutes by manufacturing configuration.

A user logs out via the menu item "Logout user" by pressing the OK button.



7.2.5 Date and time

The date and time is used as a time stamp for log. The setting is different on the touch screen and web browser.

Date

The day, month or year can be adjusted using the arrow key. By pressing once, the number is increased by one counter.

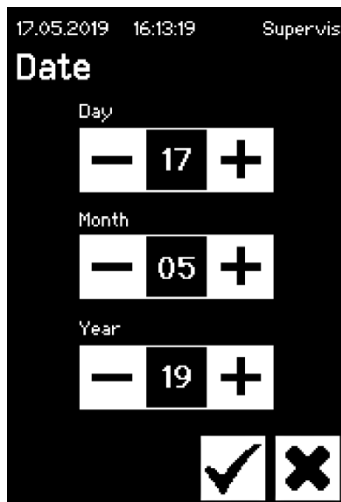

Time

The hour, minute or second can be adjusted using the arrow key. By pressing once, the number is increased by one counter.

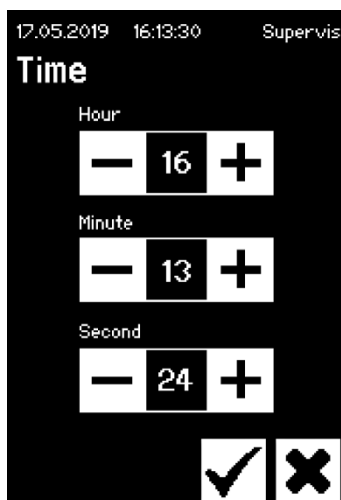

7.2.6 Language

Use the arrow keys to change the language and confirm with OK. The language is updated in operation when the device is restarted.



7.2.7 Tubing

The user has the option to select the tubing to be sealed. Depending on the choice, tubing parameters are selected (e.g. seal temperatures, closing motor positions, etc.). The user selects:

- Tubing type: This property corresponds to the material of the tubing (e.g. TuFlux[®] TPE, C-Flex[®]).
- Tubing size: This selects the geometry (ID and OD) of the tubing.

NOTICE

It is very important that the user selects the correct tubing. The sealing can fail if the selected tubing and the actually sealed tubing have different properties (geometry, temperatures, etc.).

If tubing cannot be selected, it is possible to reload new parameters. Contact your local sales representative for further information.

Tubing type

Use the arrow keys to select the type and size of tubing. Confirm with OK.

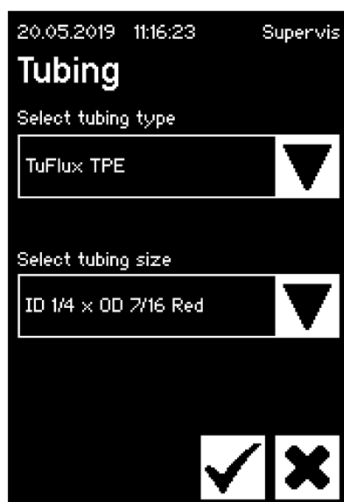

7.2.8 Network Parameters Reset

The network parameters are set to the following values with the OK key:

DHCP: Off
 Static IP address: 192.168.1.199
 Static subnet mask: 255.255.255.0

- **NOTICE** In the event of a network conflict, the network parameters can be reset to the factory settings via this menu.

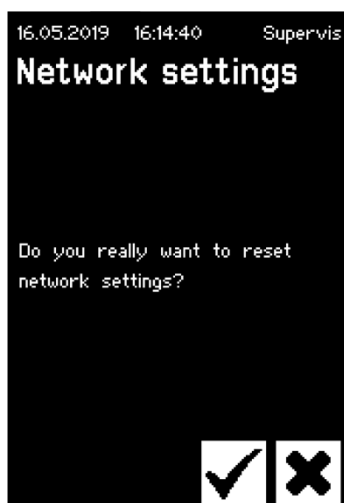





7.2.9 User administration

User administration includes all users. A user can edit his user data or those from the same or deeper user group. A user from the group "Operator" can only change his own password.

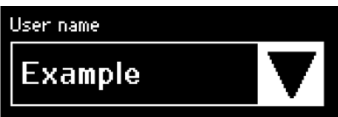
User management is divided into three different screens on the touchscreen. Please read the chapter „7.3.3 Operating elements“, page 31 for further information.

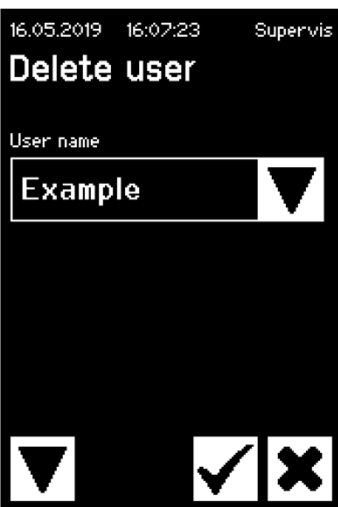
The following table shows the various screens and their parameters.

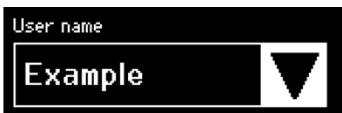
Parameter	Meaning
	<p>Screen 1</p> <p>On this screen a new user can be added or an existing user can be changed.</p> <p>Next screen with arrow down ...</p>
	<p>All users allowed to be changed are listed here. By entering a new name, a new user will be created.</p>
	<p>A password must be assigned. The password must be entered once.</p>
	<p>Each user must belong to a user group. The user group defines the authorizations. The current user cannot change his user group. Chapter „10 User groups and user interfaces“, page 40 shows all user levels and their permissions.</p>
	<p>Screen 2</p> <p>In this screen an existing user can be deleted. A user cannot delete himself.</p> <p>Next screen with arrow down ...</p>

Parameter	Meaning
	All users allowed to be deleted are listed up here.
	<p>Screen 3</p> <p>On this screen the auto login can be assigned removed to an existing user.</p> <p>Next screen with arrow down...</p>
	All users allowed to be assigned are listed here.

7.2.10 Log

For general information about log please read the chapter „9 Log“, page 38.

The output of log via the touch screen is always stored on the SD card. The SD card only serves the purpose of storing logs.

- The device does not support any kind of memory card. Therefore, a compatible card is included, imperative to use as incompatible memory cards can cause the device to malfunction.

Logs can be stored from several devices on one card. They are stored in different directories. The directory name contains the device name and the serial number and is therefore unique. The following table shows an example of the contents of a memory card.

Directory name	Log files in the directory
BSTC-101	Seal.pdf
	Seal.csv
BSTC-102	Raw.log
	Seal.pdf
	Seal.csv
	Seal.html
	State.xml
BSTC-156	Seal.pdf
	Seal.csv
	Seal.html

Directory name	Log files in the directory
BSTC-166	Raw.log
	Seal.pdf
	Seal.csv
	Seal.html
	State.xml

As you can see, the contents of the directories are different in this example. Reason: The user did not always make the same download selection.

The user has the following selection options.

Selection criterion	Meaning
Seal	Seal.pdf
	Seal.csv (depending on the settings in general parameters)
	Seal.html (depending on the settings in general parameters)
All	Raw.log
	Seal.pdf
	Seal.csv (depending on the settings in general parameters)
	Seal.html (depending on the settings in general parameters)
	State.xml

Depending on the settings in general parameters (see chapter „7.3.5 General parameters“, page 32) the csv file and the html file will be written to the SD card or not.

Selecting the date

By selecting a date, the user can specify how many logs will be downloaded to the SD card. The date entered will set the start of the period for downloading. The end date is always the current day. If entered 01/01/2001, the whole memory content will be downloaded. This may take some time!

The process of storing on the SD card is represented by a progress indicator and can be stopped like a run.

7.2.11 Info

The current status is displayed in this menu according to the following table:

Term	Meaning
IP address	Currently used assigned IP address
DHCP	Specifies whether DHCP is selected or not (Yes or No)
Serial number	The serial number of the device
Firmware	Firmware version
File system	File system version
Sealing cycle	Number of sealing cycles that the device has so far performed
Wear	The wear on the components is shown here. If one or more component reaches 100% or more, a message is displayed on the control panel. See chapter „5.5 Maintenance“, page 13.

7.3 Web browser

Working in the web browser:

- No additional software needs to be installed on the computer.
- At the same time several BioSealer® TC can be operated via one web browser.
- Operation via mobile devices such as laptops, smartphones, tablet PCs etc. possible.
- All common browsers on different platforms are supported.

Preconditions for working in the web browser:

The network parameterization in chapter „5.5 Maintenance“, page 13 was correctly carried out.

- ▶ The following web browsers are recommended:
 - Internet Explorer Version 11 or higher
 - Microsoft® Edge Version 44 or higher
 - Firefox Version 60 or higher
 - Google Chrome Version 74 or higher
- ▶ Menu items with grey background cannot be selected because preconditions are not fulfilled.

7.3.1 Connecting

Check the info menu on the touch screen for the current IP address, which must be entered in the URL bar of the browser as shown in the figure below. See also chapter „7.2.11 Info“, page 29.



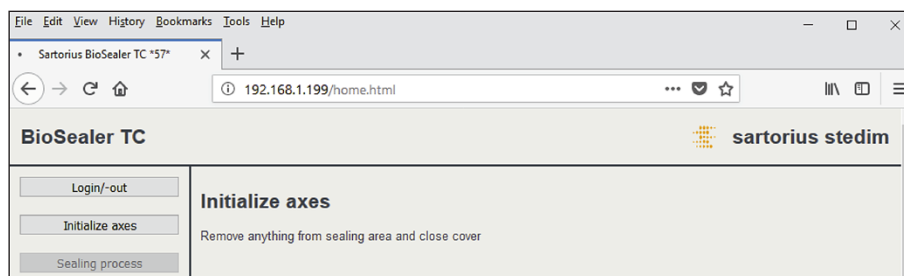



Example: The IP address of the device is “192.168.1.199” which was entered in the URL bar followed by a “return”.

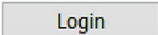
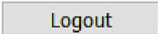

7.3.2 Menu tree

Main entries	Description
<input type="button" value="Login/-out"/>	User Login Logout, see chapter „7.3.6 User Login -out“, page 33.
<input type="button" value="Initialize axes"/>	Initialize all axes.
<input type="button" value="Sealing process"/>	Perform a sealing.
<input type="button" value="Temp. validation"/>	Validate temperature, see chapter „8.4 Temperature validation“, page 37.
<input type="button" value="General parameters"/>	General parameters, see chapter „7.3.5 General parameters“, page 32.
<input type="button" value="User management"/>	User management, see chapter „7.3.7 User Management“, page 34.
<input type="button" value="Info"/>	Info, see chapter „7.3.8 Info“, page 34.

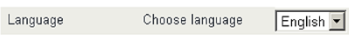
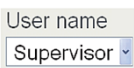
7.3.3 Operating elements

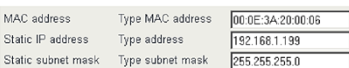
Element	Example	Description
Button		OK: accept changes
Button		Cancel: decline changes
Button		Login: login user
Button		Logout: logout user
Button		Start: start the run
Button		Stop: stop the run
Spin box		A „Spin box“ offers a choice of entries
Spin box with input		With a “Spin box with input” an additional input is possible. To do this, select the text “Type...” and enter the corresponding text using the keyboard.
Check box		With the “Check box” a functionality can be enabled or disabled.
Text box		According values can be entered. Values in the text box must make sense. The input is checked for its validity.

7.3.4 Browser appearance

The user interface consists of a header bar with product name and logo. On the left side of the browser window are the selectable menu items. In the main window, depending on the selected menu, device status or information is displayed.

The following screenshot shows an initialized device as an example. The “Initialize Axes” is greyed out and can therefore no longer be selected. The menu “Login | -out” is selected. A user with the user name “Supervis” from the “Supervisor” group is logged in.

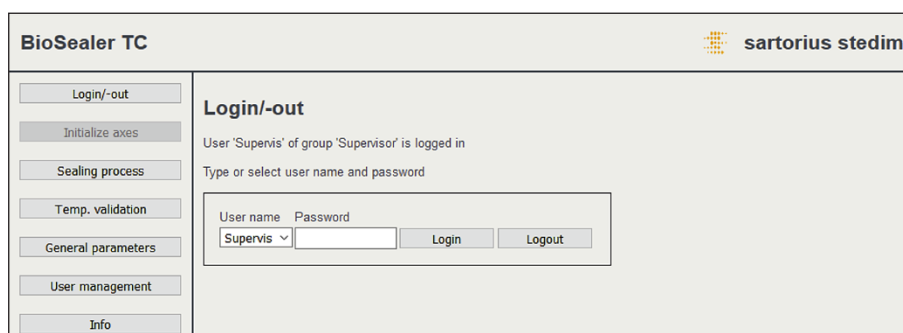

7.3.5 General parameters

General parameter is used for basic settings of the device, such as tubing selection, language or network settings.

The screenshot shows the 'General parameters' configuration window for the BioSealer TC. On the left is a navigation menu with buttons for 'Login/-out', 'Initialize axes', 'Sealing process', 'Temp. validation', 'General parameters' (selected), 'User management', and 'Info'. The main area is titled 'General parameters' and contains the following settings:

- Default tubing type: Select tubing type (C-Flex_Beta)
- Default tubing id: Select tubing size (8 (ID 1/8in x OD 1/4in))
- Fan enable: Check to enable (checked)
- Fan lag enable: Check to enable (checked)
- Fan lag temperature: in [°C] (40)
- Auto logout time: in [minutes] (10)
- Language: Select language (English)
- DHCP: Check to enable (unchecked)
- MAC address: Type MAC address (00:0E:3A:20:00:39)
- Static IP address: Type address (192.168.1.199)
- Static subnet mask: Type subnet mask (255.255.255.0)
- Static default gateway address: Type address (192.168.1.1)
- Static server address: Type address (192.168.1.1)
- Seal log screen: Check to enable (checked)
- CSV log: Check to enable (unchecked)
- HTML log: Check to enable (unchecked)

Buttons for 'OK' and 'Cancel' are located at the bottom of the configuration area.

NOTICE

It is very important that the user selects the tubing that he actually wants to seal. The sealing may fail if the selected tubing and the actually sealed tubing have different properties (geometry, temperatures, etc.).

If tubing cannot be selected, it is possible to load new parameters. Please contact your local service contact.

Parameter	Description
Default tubing type	This is the kind of tubing (e.g. TuFlux® TPE).
Default tubing size	This is the inner (ID) and outer (OD) dimension of the tubing.
Fan enable	Enables disables the use of the fan. Disabling the fan leads to long sealing cycles!
Fan lag enable	If this check box is checked, the fan lag feature is enabled. (Used for quicker cooling down of the whole device during idle state.) When the temperature of the case is above the fan lag temperature, the fan remains on until the case temperature falls below the defined fan lag temperature.
Fan lag temperature	Temperature level for the fan lag feature.
Auto logout time	Time after no activity, a user will be logged out. See chapter „7.3.6 User Login -out“, page 33 for more information.
Language	Operation language Changing the language requires a restart.
DHCP	If the device is connected to a DHCP server and the user wants to work with a dynamically assigned IP address, this checkbox must be checked.

Parameter	Description
MAC address	This address must only be changed if 2 devices in the same network have the same MAC address. The MAC addresses are assigned by the manufacturer, each device has its own address.
Static IP address	If DHCP is unchecked, this IP address will be used.
Static subnet mask	If DHCP is unchecked, this subnet mask will be used.
Static default gateway address	If DHCP is unchecked, this gateway address will be used.
Static server address	If DHCP is unchecked, this server address will be used.
Seal Log Screen	If this checkbox is checked, the seal log screen will appear at the end of a successful sealing. See chapter „9.1 Seal Log Screen“, page 39 for more information.
CSV log	If this check box is checked, the CSV seal log file will be written on the SD card when downloading the logs via touch screen.
HTML log	If this check box is checked, the HTML seal log file will be written on the SD card when downloading the logs via touch screen.

NOTICE

The network settings may only be modified by a specialist. Improper use may result in the device no longer being accessible by the web browser. The new network parameters are adopted after a restart.

If no network is used, leave the checkbox “DHCP” unchecked. This will decrease the boot up time.

7.3.6 User Login | -out

Login/-out

User 'Supervis' of group 'Supervisor' is logged in

Type or select user name and password

User name	Password		
Supervis ▾	<input type="text"/>	<input type="button" value="Login"/>	<input type="button" value="Logout"/>

Login

If no user has the attribute “auto login”, the user must log in with user name and password. Select the user name in the login | -out dialog and enter the corresponding password. Confirm the entries by pressing the “Login” button.

- ▶ If a user has the attribute “Auto login”, he will be logged in automatically after every start of the device or after a change of operation between touch screen ◀▶ web browser.

Logout

Explicit logout: After completing the work on the device, the user should logout to ensure that no other user can tamper with the device under false user name.

Automatic logout: If "auto login" is **not** selected, the system automatically logs out after a set time. This time always begins to count when the device has finished a run or when a user interaction has been performed. This time can only be changed via the Web Interface (General Parameters, Auto logout time) and is set up to 10 minutes by manufacturing configuration.

7.3.7 User Management

The user management contains all users. A user can edit his user data or those from the same or a deeper user group. A user from the user group "operator" can only change his password.

The following table shows all parameters of the user administration in the order they are listed in the web browser:

Parameter	Description
Select user or delete user	All users that the logged in user is allowed to change are listed for selection. He can also delete a user. The user cannot delete himself.
Add user	A new user can be added here. Please note that a maximum of 9 characters can be used for a user name (max. 40 users).
Password	A password must be assigned. The password must be entered twice. Please note that a maximum of 9 characters can be used for a password.
User group	Each user must belong to a user group. The user group defines the authorizations. The current user cannot change his or her user group. Chapter „10 User groups and user interfaces“, page 40, lists all users and their authorizations.
Auto login	Only one user can exclusively be assigned to automatic login. When switching on and changing the user interface, see chapter „7.1 Mutual exclusion“, page 19, the login dialog is skipped and the user with automatic login is logged in.

► Only one user can have "auto login" assigned.

7.3.8 Info

Detailed information can be downloaded from this menu. The following table lists them:

Function	Description
State	With this button, the state of the device can be downloaded. Please, always send this file with a problem report complaint.
Download log	Log files can be downloaded here. See chapter „9 Log“, page 38.
Maintenance	The wear of the components is shown here. If one or more components reach 100% or more, a message is displayed on the operation panel. See chapter „5.5 Maintenance“, page 13.
Date and Time	Synchronise date and time. See chapter „7.3.10 Date and time“, page 35.

7.3.9 Log

For general information about log please refer to chapter „9 Log“, page 38.

Under the menu “Info” the logs can be downloaded to the computer.

Selection	Description
Raw	Please, always send this file with a problem report complaint. (Used for debugging or failure analysis).
Seal (pdf)	Seal log as a pdf file
Seal (HTML)	Seal log as a self-validating HTML file
Seal (CSV)	Seal log as comma-separated values file

- ▶ **NOTICE** When the log is downloaded via web browser, not all the data stored in the device are downloaded. The most current logs up to a file size of approx. 500 kByte will be downloaded.

7.3.10 Date and time

Under the menu “Info” date and time can be synchronized with the computer on which the browser is running. Push the button: “Synch BioSealer® TC with this Host”.

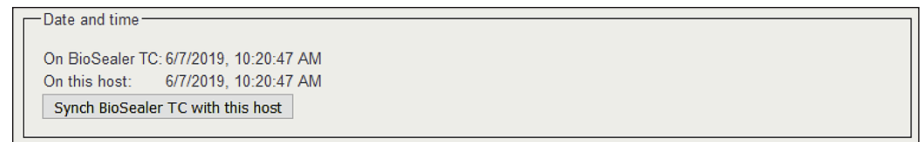

- ▶ Date and time on the host need to be accurate.

8 Runs

Runs are fully automated processes, which are carried out as soon as the cover is closed. A run is terminated when the cover opens. At the user interface, only processes are provided for which the user has the authorisation and which he can execute with the current device status.

Examples:

- An "operator" cannot start a validation.
- A sealing is only possible after initialization has been performed successfully.

The following chapters explain the individual runs.

8.1 Initialize axes

All axes are initialized during this run. During the initialization all components of the system are tested.

- ▶ The device decides when an initialization is necessary and prompts the user to perform it e.g. after switching on the device or if tubing with a different outside diameter has been selected.

The initialization is initiated by closing the cover and can be stopped at any time. The initialization run is then aborted. An initialization can be restarted at any time.

8.2 Sealing

The sealing process is described in the chapter „4.4 Function“, page 9. How a sealing run is initiated can be read in the chapter „8 Runs“, page 36.

- ▶ A sealing cannot be cancelled by the user or by a power fail.

8.3 Power failure

It is strongly recommended to ensure that the power retains on a steady level (according to chapter „14 Technical data“, page 46) as the device may produce bad sealings during a power failure.

The following table shows what happens after a power failure in different runs.

Run	During power fail	After restart
Initialization	No reaction	Cover opens, ready to initialize
Sealing	Various states of the device are stored	A power failure message is displayed. After pressing OK, the sealing will be continued.
Temperature validation	No reaction	Message to remove validation holder.
No run	No reaction	A power failure is not displayed. If the user made changes before the power failure occurred (e.g. parameters changed) he must check if these changes have been saved.

- ▶ **NOTICE** If a power fail happened during a sealing, the sealing will be completed by a special run. Please double check the quality of the sealing very accurately!
- ▶ The seal log screen will not appear after a sealing with power fail, because it was not a normal sealing. In the log file, there will be an event called "Reseal".

8.4 Temperature validation

- ▶ A separate validation tool needs to be bought for validating the temperature.
- ▶ The BioSealer® TC must be initialized to use this function.

User steps:

1. Press the "Temperature validation" symbol
2. Remove anything from the squeeze axis and close cover
3. Insert the validation holder and close cover

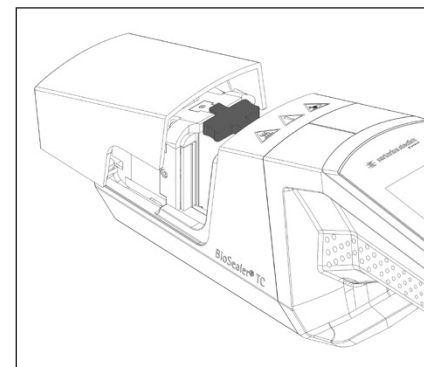
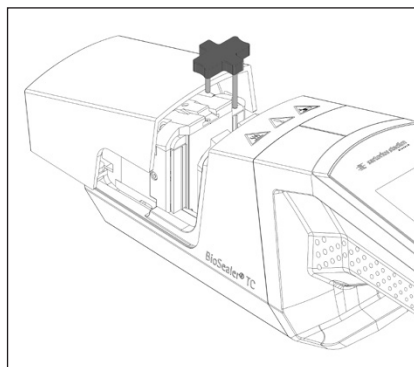

4. Press Start to begin the validation cycle
5. Remove the validation holder and press the cancel button.

The validation cycle is defined by default as following:

1. 130°C ($\pm 5^\circ\text{K}$)
2. 150°C ($\pm 5^\circ\text{K}$)
3. 170°C ($\pm 5^\circ\text{K}$)

If the temperature is out of specification, please contact your local service contact.

8.5 Service position

- ▶ This position is used for cleaning the device and to remove stuck tubing.
- ▶ This function is only available via the touchscreen.
- ▶ **NOTICE** If this function is used to remove stuck tubing, set clamps before activating this function!

User steps

1. Press the "Service position" symbol
2. Remove anything from the squeeze axis if possible, set clamps if necessary and close cover
3. Press Start to bring the device into the service position (The squeeze axis will open up as much as possible.)

9 Log

BioSealer® TC records runs for its on-going operation and saves them. A circular buffer is provided for this purpose. If the memory is full (capacity of around 50,000 sealings) and a new log appears, the oldest log is deleted permanently and the new log is saved. Depending on setting and operating mode, it is possible that recordings are never overwritten even if the device has executed thousands of sealings.

These recordings can be copied to a storage medium through the Web browser or through the touch screen. See chapter „9 Log“, page 38 for touch screen or chapter „7.3.9 Log“, page 35 for the Web browser.

The output format of the weld log is pdf, csv or html. To read a csv file, various tabular calculation programs such as Microsoft Excel or OpenOffice Calc can open these files without problem or import functions for databases can be written. To open a html file, use a Web browser such as Firefox, Google Chrome or Internet Explorer.

The html file has a self-validation function built in. This function prevents accidentally altering of the data stored inside the html log file. At the end of the file it shows either "Valid" in green if the data is correct and not altered or "not Valid" in red if data was altered.

► **NOTICE** A criminal action cannot be prevented with this self-validation function!

The internal memory of the BioSealer® TC has a capacity of around 50,000 Seal Logs. If the memory is full, the oldest entries will be overwritten without warning.

The customer is responsible to archive the downloaded seal logs.

The following table lists all logs and their content which the device outputs:

Seal log	The seal log is a table with the following columns:	
	Date	The date when the sealing was performed (dd.mm.yyyy).
	Time	The time when the sealing was performed (hh:mm:ss).
	User	The user who performed the sealing.
	Tubing type	For the sealing selected tubing type, e.g. C-Flex® 374.
	Tubing description	For the sealing selected dimensions, e.g. ID ¾ in × OD 1 in
	Cycle	Unique sealing number for this sealing (increments after every sealing).
	Step 1 Temperature	Current temperature at step 1
	Step 2 Temperature	Current temperature at step 2
	Seal time	Time between start heating and end position reached
	Process time	Time between start heating and start squeeze drive reversing (release temperature reached and press end time reached)
	Code	Manufacturer internal code
	Event	Important event during the sealing such as blocked condition, etc.

Log	Content
Raw log	Please, always send this file with a problem report complaint (used for debugging or failure analysis).
Status	Please, always send this file with a problem report complaint (used for debugging or failure analysis).

The seal log is always output in the language that is currently chosen.

9.1 Seal Log Screen

The seal log screen shows all relevant information about the sealing just finished. It is intended to use in a GMP | FDA approved environment where such data needs to be archived. The user can either write it down on a protocol or take a picture with a camera.

► **NOTICE** The seal log screen appears only after a successful sealing.

This feature can be enabled | disabled via the Web interface. See chapter „7.3.5 General parameters“, page 32.

10 User groups and user interfaces

The following table shows the authorizations of user groups and the user interfaces.

User group	Operator control	Function		Comments	
		Group or menu item	Detail		
Operator	Touch screen and Web browser	Initialize axis			
		Seal			
		Log in			
		Log out			
		Parameter	User Management	Only the user's own password, no assignment by auto login	
		Touch screen	Info		
		SD card			
Supervisor	Touch screen and Web browser	Validate			
		Parameter	Type of tubing		
			Language		
			User Management	No restriction for the processing of users from the user's own group or those of a lower level	
	Web browser	Parameter	DHCP		
			MAC address		
			Static IP address		
			Static subnet mask		
			Static default gateway address		
			Static server address		
		Info			
	Touch screen		Service position		
Time					
Date					
Network reset					

- The two user groups are indicated in the "User group" column. Operator group has lower-level authorizations and Supervisor group has higher-level authorizations. A higher-level always includes the authorizations of a lower-level. The "Operator control" column indicates which user interface supports which function.

Whether a function is usable depends on the device status. Sealing, for example is impossible if no initialization is done or if the device is blocked. These limitations are not visible here.

Example: A user from the Supervisor group can validate, but a user from the Operator group cannot.

11 Operating problems

11.1 Switch off the device

The BioSealer® TC cannot be switched off during a run. After the run has finished, the device can be switched off by pressing the power button for a few seconds.

NOTICE

Before the device is switched off by the user, wait until the current run has ended.

11.2 Foreign objects in the device

The BioSealer® TC is a fully automatic device with several electromechanical drives which in some cases generate very high forces.

NOTICE

It is important to ensure that no foreign objects enter the mechanics. This can lead to a blockage or even to a defect of the device.

11.3 Incorrect tubing inserted

The tubing is not automatically recognised by the device. The tubing selection can only be changed by the user group "Supervisor". It is possible that the user inserts incorrect tubing.

The consequence may be that the sealing quality is insufficient or the sealing is broken off.

- ▶ **NOTICE** Be sure to insert only tubing which are displayed on the user interface. Compare tubing type, inner and outer diameter!

NOTICE

If an incorrect tubing is selected, damage can result.

11.4 Memory card

The SD memory card is not recognised by the device.

Possible causes: The SD card supplied by the manufacturer has not been used, the card is defective or has not been formatted FAT32.

11.5 Lost password

If a password is lost, it must be reset. There are two ways to reset the password:

- Another user from the user group "Supervisor" can reset the password.
 - Use the emergency login to reset the password. The access data for the emergency login must be requested from the responsible technician.
- ▶ Users from the user group "Operator" can only change their own password.

11.6 Manual cover opening

If the cover does not open after several attempts, it might be necessary to open it manually. For this purpose, a small hole was created on the bottom of the stainless steel case. Insert a small needle or similar and proceed as shown in the pictures below.

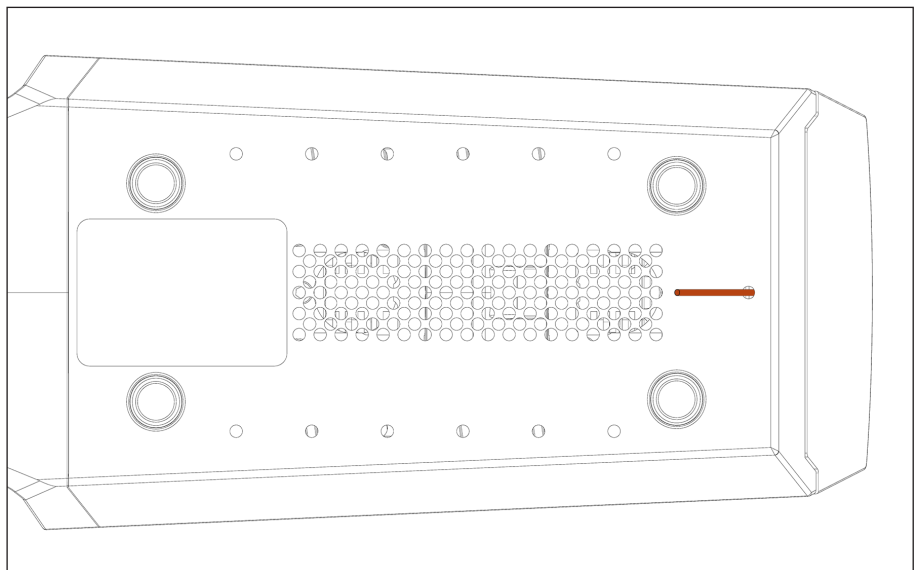
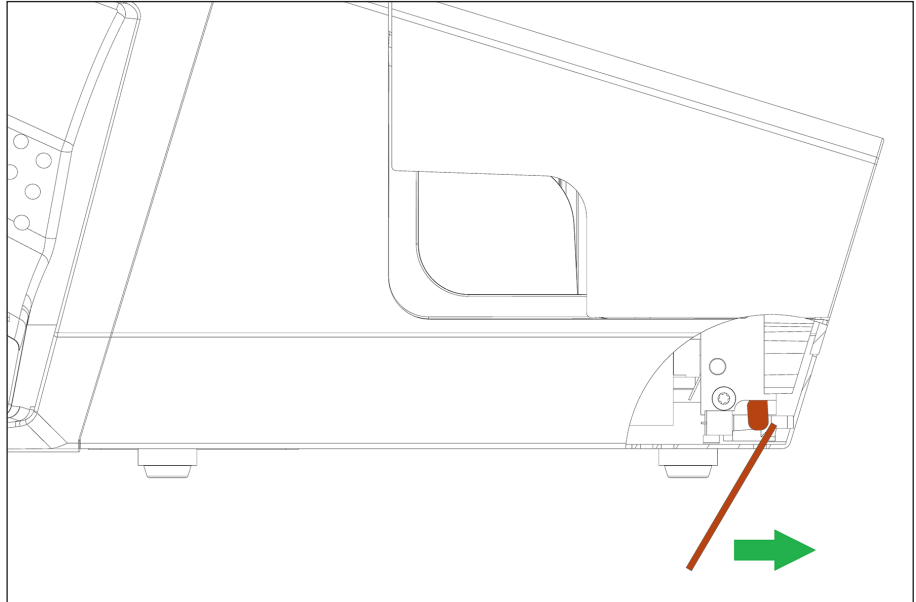

12 Error reports and Warning messages

The following tables list error reports and warning messages which can appear in the operator control.

Error message	Remark
All runs blocked (0)	The source of this error is the cover unit. First try to reboot the device. If this does not solve the problem, try to manually open the cover. See chapter „11.6 Manual cover opening“, page 42.
All runs blocked (1)	The source of this error is the moving cooling unit. Switch the device off and let it cool down for at least half an hour. Then try again.
All runs blocked (2)	The source of this error is the fixed cooling unit. Switch the device off and let it cool down for at least half an hour. Then try again.
All runs blocked (3)	The source of this error is the squeeze drive. Make sure there are no obstacles in the sealing area. Reboot the device and try again. If the error appears again, reboot the device and use service position (see chapter „8 Runs“, page 36). Check again for obstacles in the sealing area. Then try again.
All runs blocked (5)	The source of this error is the heating system. Reboot the device and try again. If it unsuccessful, let the device cool down for at least half an hour and try again.
All runs blocked (7)	The source of this error is a fan. Check if no obstacles are in the sealing area.

If an all runs blocked remains, contact your local service representative. Do not continue to use the device!

Warning messages	Possible cause	Elimination
Insert validation holder	Validation holder is not inserted or not inserted correctly.	Insert validation holder.
Remove validation holder	Validation holder is inserted but should be removed.	Remove validation holder.
SD missing. Please insert SD and retry!	SD card is not inserted.	Insert SD card.
SD not valid	SD card is not supported.	Try to format the SD card with FAT32.
Power failure! Read manual	Power failure occurred during the sealing process.	Read chapter „8.3 Power failure“, page 36.
Case temperature too high	The case temperature is too high.	Let the device cool down.
Input voltage too low	The input voltage of the device is too low.	Use only one extension cable!
Remove anything from sealing area.	There might be something in the sealing area.	Remove anything from the sealing area.
There are no valid parameters on this device. Load parameters.	Unknown	Contact your local service contact.
No valid default tubing found	Unknown	Contact your local service contact.
Invalid date	Not an existing date e.g. 31.02.2019	To set the date, specify a valid date.
	Date specified in the future for log download.	To download log, select a date in the past.

If a warning message remains, contact your local service contact. Do not continue to use the device!

13 Disposal

13.1 Information on Decontamination

The device does not contain **any** hazardous materials that would necessitate special disposal measures. The cultures and media (e.g. acids, bases) used during the sealing process are potentially hazardous materials that could cause biological or chemical hazards.

According to the EU directives (European directive on hazardous substances), the owner of devices that come into contact with hazardous substances is responsible for properly disposing of those devices and for declaring such devices when transporting them.

If the device has come into contact with hazardous substances: Measures must be carried out to properly decontaminate and declare such devices. The operator is responsible for adhering to local legislation on the proper declaration of transport and disposal and the proper disposal of the device.

WARNING

Risk of injury due to contaminated equipment!

Devices contaminated with hazardous materials (nuclear, biological or chemical (NBC)) will **not** be accepted for repair or disposal.

13.2 Disassembly

Requirements

- The device has been taken out of operation.
- Download all log data.
- Switch off the device and disconnect it from the power supply.

WARNING

Danger of injury due to sharp parts!

- ▶ Wear personal protective equipment.
-

Procedure

- ▶ Disassemble the device and all parts until all parts have been assigned to a material group; and can be appropriately disposed of.

13.3 Disposing of Device and Parts

13.3.1 Information on Disposal

The device and the accessory must be disposed of properly by disposal facilities.

A battery is installed inside the device. Batteries must be disposed of properly by disposal facilities.

The packaging is made of environmentally friendly materials that can be used as secondary raw materials.

13.3.2 Disposal

Requirements

The device has been decontaminated.

Procedure

- ▶ Dispose of the device. Follow the disposal instructions on our website (www.sartorius.com).
- ▶ Dispose of the packaging in accordance with local government regulations.

14 Technical data

14.1 Device

Type designation	BioSealer® TC
Input voltage	24 VDC
Supply current	6.25 A
In and out connections	Device plug XLR max. 24 VDC Ethernet jack type RJ45
Operating temperature	+5°C - +40°C
Place of use	Indoor (Laboratory)
Pollution degree	2
Humidity	80% up to 31°C, linearly diminishing to 50% relative humidity at 40°C, not condensing
Altitude	Up to 2,000 m
Degree of protection	IP20
Mass	Approx. 3 kg
Outer mass (L×W×H)	391 mm × 115 mm × 147 mm

14.2 Power supply

Input Voltage	100 VAC – 240VAC
Input frequency (power supply)	47 Hz – 63 Hz
Input current (power supply)	2.5 A
Power cord	According to local regulations minimum 3 × AWG18 or 3 × 0.75mm ² minimum local mains supply voltage

14.3 Dimensions

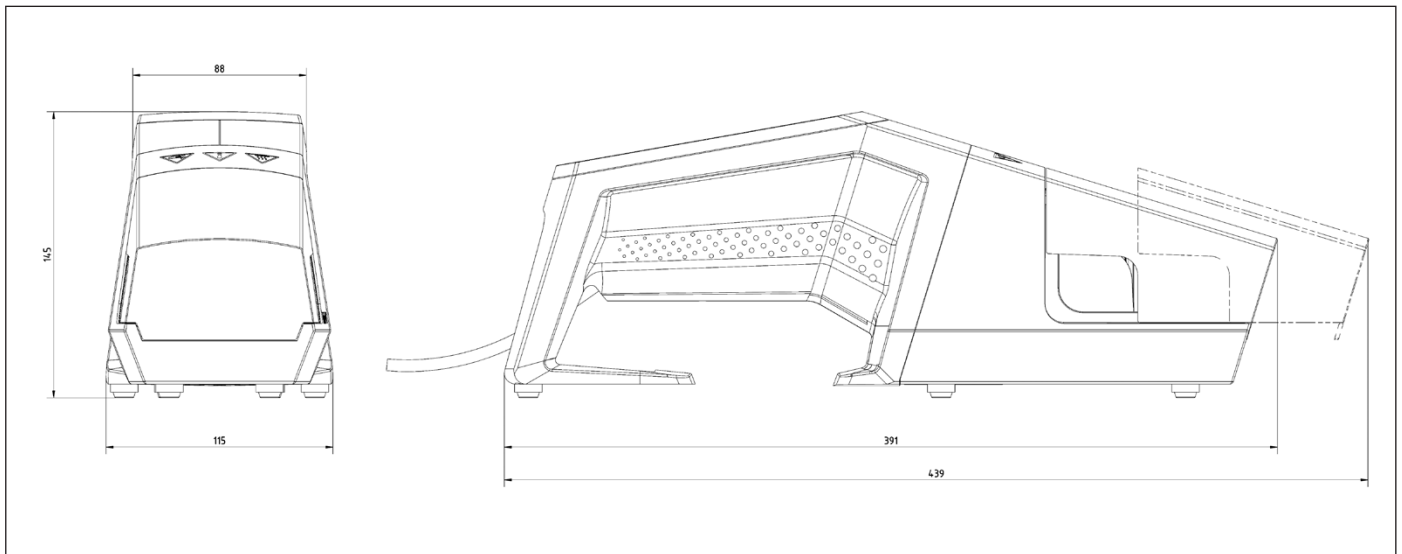

15 Appendix

15.1 Copyright

C-Flex[®], SaniPure[™] and PharMed[®] are registered trademarks of Saint-Gobain Performance Plastics Corporation.

Parts of the device are patented. No part of this device may be reproduced, distributed, translated or transmitted in any form or by any means, electronic or mechanical, including photocopying, recording or storing, in an information storage and retrieval system, without the prior written consent of Reed Electronics AG.

15.2 Technical contact

Sartorius Stedim Switzerland AG
Ringstrasse 24a
CH-8317 Tagelswangen

+41 52 354 36 17

TechSupportTAG@sartorius.com

Sartorius Stedim Biotech GmbH
August-Spindler-Strasse 11
37079 Goettingen, Germany

Phone: +49.551.308.0
www.sartorius.com

The information and figures contained in these instructions correspond to the version date specified below.

Sartorius reserves the right to make changes to the technology, features, specifications and design of the equipment without notice.

Masculine or feminine forms are used to facilitate legibility in these instructions and always simultaneously denote the other gender as well.

Copyright notice:

This instruction manual, including all of its components, is protected by copyright. Any use beyond the limits of the copyright law is not permitted without our approval. This applies in particular to reprinting, translation and editing irrespective of the type of media used.

© Sartorius Germany

Last updated:
07 | 2019