

Operating Manual

PMA.Evolution | PMA.HD

EV01X | LAB1X

Paint-mixing Scales for Use in Potentially Explosive Atmospheres



Contents

1 About This Document	4	7 Care and Maintenance	33
1.1 Scope.....	4	7.1 Cleaning.....	33
1.2 Symbols Used.....	4	7.2 Maintenance.....	33
1.3 User Information.....	4	8 Malfunctions	34
2 Safety	5	9 Storage	35
2.1 General Safety Instructions.....	5	10 Disposal	35
2.2 Installation Instructions.....	6	11 Serial Number Coding	36
2.3 Intended Use.....	7	12 Technical Data	37
3 Device Overview	8	12.1 General Data.....	37
3.1 Front View.....	8	12.2 Model-specific Data.....	38
3.2 Rear View.....	9	12.3 Verified Models with EC Type Approval Certificate: Model-specific Technical Data.....	38
3.3 Ex-link Converter/AC Adapter.....	10	12.4 Device Dimensions.....	39
3.4 Operating and Display Elements.....	11	12.4.1 Model EVO1X.....	39
3.5 Menu List.....	13	12.4.2 Model LAB1X.....	39
4 Installation	17	12.5 USB Port (PC Connection).....	39
4.1 Unpacking and Equipment Supplied.....	17	12.5.1 Purpose.....	39
4.2 Selecting a Setup Location.....	17	12.5.2 Installing the Software Driver.....	40
4.3 Installing the Scale.....	18	13 Accessories	41
4.4 Supply Voltage.....	18	14 Sartorius Service	42
4.4.1 Power Supply Assembly.....	18	15 Conformity & Licenses	42
4.4.2 Connecting the Scale.....	20	15.1 EU Declaration of Conformity.....	42
4.5 Anti-theft Locking Device.....	22		
5 Commissioning	23		
5.1 Leveling.....	23		
5.2 Warm-up Time.....	23		
6 Operation	24		
6.1 Switching the Device On/Off.....	24		
6.2 Locking the Keypad/Weight Display.....	24		
6.3 Zeroing/Taring.....	24		
6.4 Calibration/Adjustment.....	24		
6.4.1 Calibration.....	25		
6.5 Weighing.....	25		
6.5.1 Weighing with One Decimal Place.....	25		
6.5.2 Weighing with Two Decimal Places (Not for Verified Models).....	26		
6.6 Applications.....	26		
6.6.1 Calculation by a Factor.....	26		
6.6.2 Weighing Using the Recalculation Function.....	27		
6.7 Menu Settings.....	29		
6.7.1 Accessing the SETUP Menu.....	29		
6.7.2 Configuring the Main Menu Settings.....	29		

1 About This Document

1.1 Scope

This operating manual applies to paint-mixing scale models:

- EVO1X
- LAB1X

1.2 Symbols Used

Denoting instructions and direct hazard warnings, all especially important statements to be observed in these installation instructions will be marked as follows:



This symbol denotes a possible danger with medium risk of death or (severe) injury if not avoided.



This symbol denotes a possible danger with a low risk of moderate or minor injury if not avoided.



This symbol denotes a danger with low risk that could result in property damage if not avoided.



This symbol

- is an indication of a function or setting on the device
- is an indication that caution should be exercised while working
- identifies useful information.



This symbol provides information for the sale of scales verified for use in legal metrology. In the following, the term "verified" is used to mean "verified for use in legal metrology" or "conformity-assessed."

The following symbols are also used:

- Text that follows this symbol is a list.
- ▶ Text that follows this symbol describes activities which are to be performed in the specified order.
- ▷ Text that follows this symbol describes the result of an action.

1.3 User Information

The illustrations in these instructions are based on the PMA.Evolution (EVO1X) model.

2 Safety

2.1 General Safety Instructions

- The scale and the ex-link converter meet the relevant legal provisions and applicable standards (see the corresponding certificates in Chapter 15, page 42).
- Nevertheless, improper use or handling can result in damage and/or injury. Any improper use or operation of the scale or of the ex-link converter, i.e., that is not consistent with the instructions, will result in forfeiture of all claims under the manufacturer's warranty.
- Personnel need to have read and understood these installation instructions, including the safety instructions.
- In the event of use in systems and under ambient conditions with higher safety requirements, you must observe the requirements and provisions applicable in your country.
- Always keep the equipment and scale freely accessible.



Ensure that the voltage rating printed on the AC adapter (optional) is identical to your local mains voltage.



The IP protection rating of the scale and the ex-link converter YCO14-Z/YCO14-Y is IP40 as per EN 60529. The devices must be handled carefully according to the IP protection rating. The environment must be suitably secured.

Use within the scope of validity of the European ATEX Directive:

- In accordance with Directive 2014/34/EU, the model in the EVO1X | LAB1X series is a category 2 device, suitable for use in Zone 1 potentially explosive areas.
- The ex-link converter YCO14-Z is only suitable for installation as an associated electrical apparatus with the following ID code outside of the potentially explosive area.
- The ex-link converter YCO14-Y is an associated electrical apparatus that can be used in Zone 2.
- Refer to the EU Type Examination Certificates in Chapter 15, page 42 for the device ID codes. Please observe the safety instructions in drawing 2023040 in Chapter 15, page 42.

Use in Canada and the USA:

The intrinsically safe scales in the EVO1X | LAB1X model series are suitable for use in Class I, Division 1 and Class I, Zone 1. The ex-link converter YCO14-Y can be used in Class I, Division 2 and Class I, Zone 2.

Please observe Certificates of Conformity FM16US0226X and FM16CA0124X as well as Control Drawing 2021459 in Chapter 15, page 42.

Use in Australia/New Zealand:

Please observe IECEx Certificate of Conformity IECEx FME 14.0008X and Safety Instructions 2023040 in Chapter 15, page 42.

2.2 Installation Instructions



Do not operate the scale if its housing, the ex-link converter, or the AC adapter including all connections are damaged.
Immediately disconnect the damaged device from the power.



Do not expose the scale, the ex-link converter, the AC adapter, or the accessories supplied by Sartorius to extreme temperatures, aggressive chemical vapors, moisture, shocks, vibrations, or strong electromagnetic fields. Observe the conditions of operation described in the Specifications.
The connection cables between the devices as well as the casing on the wires inside the device housing are made of PVC. Chemicals that corrode this material must be kept away from these cables.



The operator shall be solely responsible for any modifications to the equipment and for connecting any cables or equipment not supplied by Sartorius. Information on operational quality is available upon request from Sartorius.
Only use original Sartorius accessories!



Note the IP protection rating of the scale, the ex-link converter, and the AC adapter. Do not allow liquid penetration. The protection rating specifies the suitability of equipment for various environmental conditions (moisture, foreign bodies).



Before cleaning the AC adapter, ex-link converter, or the scale:
Disconnect all devices from the power supply.



The scale and ex-link converter may only be opened by personnel trained by Sartorius with the power disconnected.
Do not open the AC adapter.



Avoid generating static electricity on the glass panel of the touch screen and plastic casing. The equipotential bonding conductor of the devices must be connected properly, according to commonly accepted technical standards.
Only clean the device as stipulated in the cleaning instructions.



Take care that the glass panel of the touch screen is not damaged (e.g., by falling objects, impact, or extreme pressure).
If the glass panel is damaged, disconnect the device from the power supply immediately.



The surface of the touch screen should not be touched with pointed, sharp, hard, or rough objects. You should only use the touch pen provided or your fingertips. Do not use parts of clothing (e.g., sleeves) or sponges for cleaning because these can scratch the surface (e.g., due to rivets or buttons in the sleeve, or sand in the sponge).
The device must be protected from unnecessarily extreme temperatures, aggressive chemical vapors, moisture, shocks, and vibrations. Note the connection data (see EC Type Examination Certificates for the device and/or the safety instructions, drawing no. 2023040).

Warnings Concerning Installation and Operation:



The equipment must only be used indoors. Avoid generating static electricity on glass and plastic parts. Connect the scale and the ex-link converter to the equipotential bonding conductor using a suitable low-resistance method. All electrical circuits are grounded and electrically connected to the metal parts of the devices.

- The installation must be checked for correct function and safety by trained and qualified personnel at appropriate intervals (e.g., checking the cables for damage).
- Operating personnel must be trained to recognize faulty operating states and to be able to initiate the necessary safety measures (e.g., disconnecting the ex-link converter from the power supply).



Lay the cables where they pose no risk of causing someone to trip.



Danger of Scale Damage!

Never close a paint can using a hammer while it is still on the weighing pan. When closing, place the paint can on a firm, stable surface.

Observe the additional safety precautions and hazard warnings in subsequent chapters.

2.3 Intended Use

This scale is only intended for mixing colors and paints. The scale is connected to the ex-link converter only using the link cable supplied. The scale and ex-link converter may only be used in potentially explosive areas in accordance with Safety Instructions 2023040 in Chapter 15, page 42. Appropriate containers must be used for loading each type of material.

The scale can be operated via the keypad as a stand-alone device or using application software (e.g., a paint-mixing program from a paint manufacturer) installed on a connected PC. The PC is connected to the ex-link converter via a USB cable.

3 Device Overview

3.1 Front View



Item	Designation
1	Operating and display elements (see also Chapter 3.4, page 11)
2	Support column
3	Weighing pan

3.2 Rear View

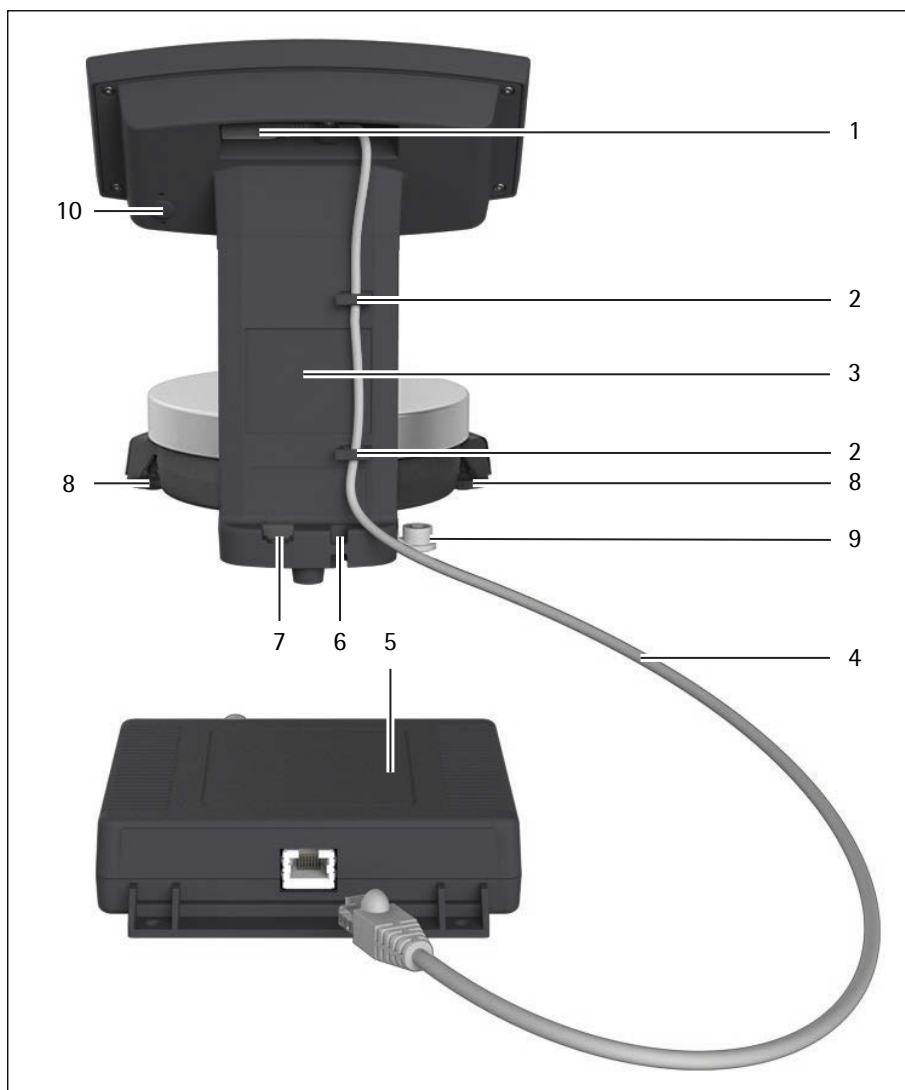

Item	Designation
1	RJ-45 socket for link cable
2	Cable holders
3	Support column
4	Link cable (blue)
5	Ex-link converter
6	Anti-theft locking device
7	Grounding terminal for equipotential bonding
8	Leveling feet (PMA.HD and verified models only)
9	Leveling (PMA.HD and verified models only)
10	Menu access switch

3.3 Ex-link Converter/AC Adapter

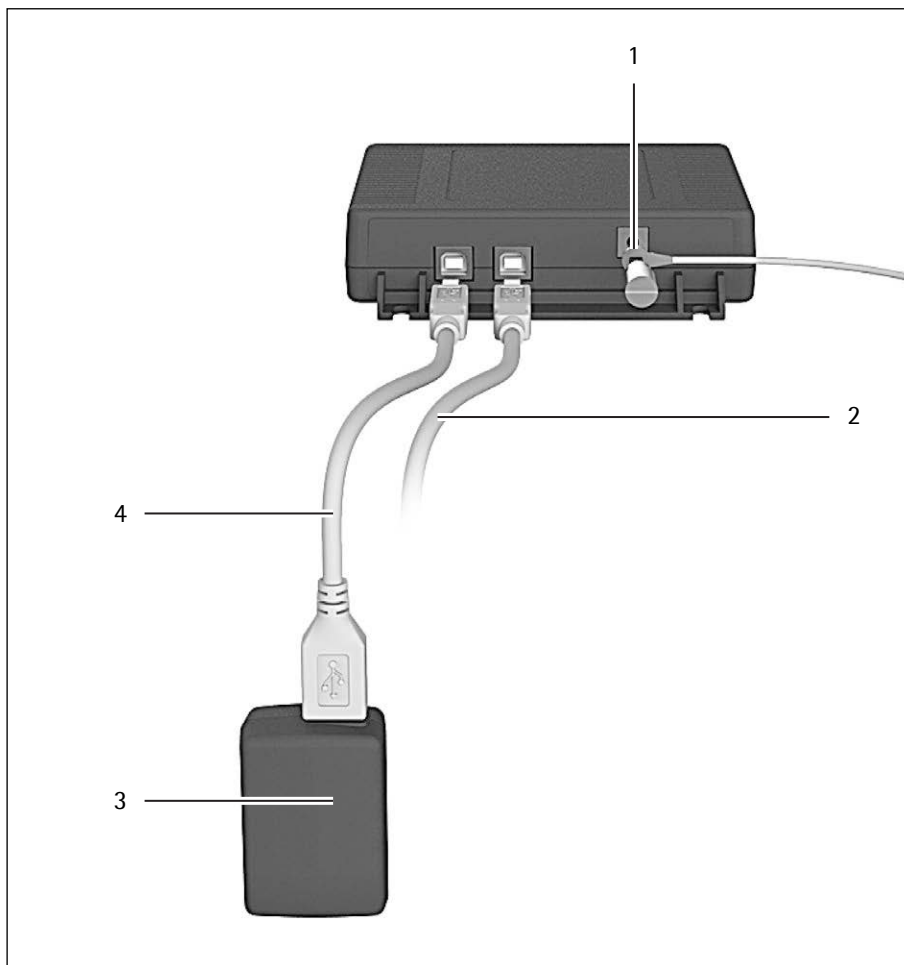

Item Designation

1	Grounding terminal for equipotential bonding
2	USB cable for connecting to PC or notebook. If the ex-link converter YCO14-Y is in Zone 2 or Division 2 as per the Safety Instructions or Control Drawing (Chapter 15, page 42) and the USB cable does not have an intrinsically safe electrical circuit with protection rating Ex ic or an NIFW electrical circuit (for Division 2), the cable must be secured against disconnection (see Chapter "4.4.2 Connecting the Scale," page 20).
3	Power supply (figure may deviate from product). (Figure may deviate from product)
4	USB cable for power supply via the AC adapter (optional) The AC adapter is only approved for the ex-link converter power supply if the ex-link converter is installed outside of the potentially explosive area.

3.4 Operating and Display Elements



Sharp or pointed instruments (such as ballpoint pens) can damage the device!

- The touch screen should only be operated by lightly pressing it using the tips of your fingers.

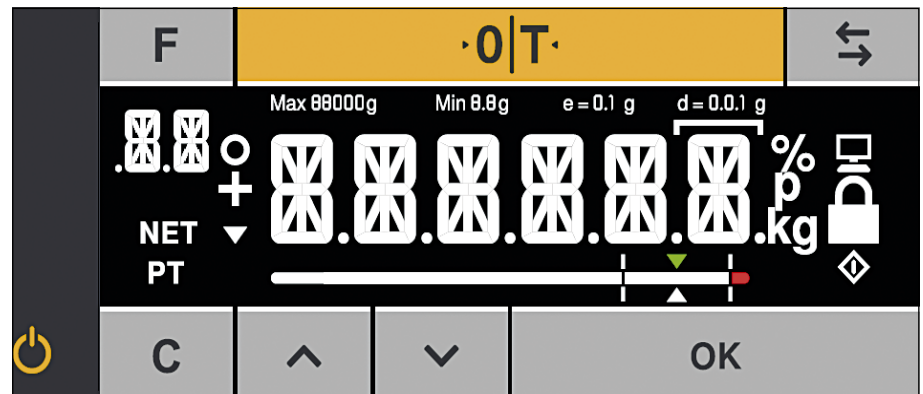

Key Function

F	Factor key for paint-mixing applications
0 T	Zeroing/taring
↔	Toggle key: Toggles the decimal places and/or unit Depends on the menu setting
⏻	On/standby
C	Clear key/display of correction factor for paint-mixing applications
^	Up
v	Down
OK	ENTER key/MEM key for paint-mixing applications

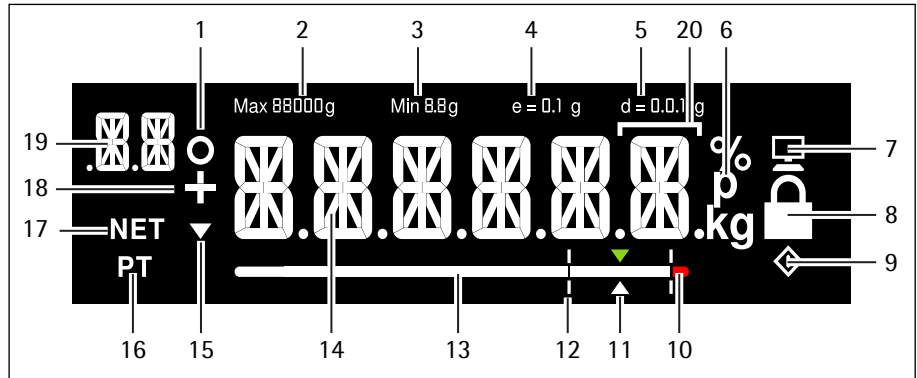

Item Function

1	Activated function in the menu list (see Chapter 3.5, page 13) Symbols for zero range (verified models only)
2	Maximum weighing range
3	Minimum load Min (verified models only)
4	Verification scale intervals (verified models only)
5	Readability of the scale (scale interval d)
6	Weight unit and stability indicator
7	Communication with the PC
8	Activate "LOCK" function, or function activated
9	◆ symbol: Indicates that an internal process is in progress For verified models: Indicates an invalid weight value
10	Tolerance range has been exceeded
11	Target value for bar graph
12	Tolerance range
13	Bar graph: Scaled display showing capacity usage (in percent)
14	Fourteen segment display
15	Trend display
16	Info on weight entry via application keypad (preset tare)
17	Net value
18	Plus (or minus) sign of the weight
19	Display: - SETUP level - Component/factor for paint-mixing applications
20	In verified mode for devices where $e \neq d$: The frame indicates a scale interval (standard scale interval d is smaller than verification scale interval e)

3.5 Menu List

The "o" in the active column indicates the activated function in the respective menu.

Level 1	Level 2	Level 3	Active	Level 4	Function	CODE
SETUP						1.
	-----	SCALE				1.1
		----			Installation site	1.1.1
				V.STABL.	Very stable ambient conditions	1.1.1.1
			o	STABLE	Stable ambient conditions	1.1.1.2
				UNSTAB.	Unstable ambient conditions	1.1.1.3
				V.UNSTAB.	Very unstable ambient conditions	1.1.1.4
		----			Application filter	1.1.2
				FIN.RD.	Final readout	1.1.2.1
			o	FILL.WT.	Filling weight	1.1.2.2
		----			Stability range/stability	1.1.3
				1/2-DIG.	1/2 digit/good	1.1.3.2
				1-DIG.	1 digit/normal	1.1.3.3
			o	2-DIG.	2 digits/sufficient	1.1.3.4
				4-DIG.	4 digits/low	1.1.3.5
		----			Automatic zero/drift correction	1.1.6
				ON	On	1.1.6.1
			o	OFF	Off	1.1.6.2
		----			Weight units	1.1.7
			o	GRAMS	Grams	1.1.7.2
				PT.P.LB	Parts per pound ¹⁾	1.1.7.14
		----			Accuracy ¹⁾	1.1.8
			o	ALL	Show all decimal places	1.1.8.1
				POLYR.	Multi-interval lab	1.1.8.13
		----			Calibration/adjustment	1.1.9
			o	CAL.EXT.	External calibration/adjustment with default weight	1.1.9.1
				LOCKED	CAL key/command locked	1.1.9.10
		APP.PRG.				1.3
		----			2nd unit ¹⁾	1.3.1
			o	GRAMS	Grams	1.3.1.2
				PT.P.LB	Parts per pound	1.3.1.14
		----			Accuracy 2nd unit ¹⁾	1.3.2
				ALL	Show all decimal places	1.3.2.1
			o	POLYR.	Multi-interval lab	1.3.2.13
		----			Toggle key on/off ¹⁾	1.3.3
			o	OFF	Toggle key off	1.3.3.1
				ON	Toggle key on	1.3.3.2

Continued on next page

¹⁾ Not available on scales verified for use in legal metrology

Level 1	Level 2	Level 3	Active	Level 4	Function	CODE
{SETUP}	---	REC.MOD.			Recalculation	1.3.4
		----	o	TOTAL	Gross weight	1.3.4.1
		----		INDIV.	Individual	1.3.4.2
	GEN.SRV.					1.9
	---	MEN.RES.			Menu reset	1.9.1
		----		DEFAULT.	Load default menu	1.9.1.1
		----	o	NO	Stand-by	1.9.1.2
DEVICE						2.
	----	EXTRAS				2.1
		---			Menu	2.1.1
		----	o	ENABLE	Menu can be edited	2.1.1.1
		----		RD.ONLY.	Menu read only	2.1.1.2
		---			Key function enabled/locked	2.1.3
		----	o	ENABLE	Keypad enabled	2.1.3.1
		----		LOCKED	Keypad locked	2.1.3.2
		---			Background light	2.1.4
		----		10 PCT.		2.1.4.1
		----		20 PCT.		2.1.4.2
		----		30 PCT.		2.1.4.3
		----		40 PCT.		2.1.4.4
		----		50 PCT.		2.1.4.5
		----		60 PCT.		2.1.4.6
		----	o	70 PCT.		2.1.4.7
		----		80 PCT.		2.1.4.8
		----		90 PCT.		2.1.4.9
		----		100 PCT.		2.1.4.10
		---			Bar graph on/off	2.1.5
		----		OFF	Display without bar graph	2.1.5.1
		----	o	ON	Display with bar graph	2.1.5.2
		---			Switch-on behavior	2.1.6
		----	o	ON/STB.	On/standby	2.1.6.3
		----		AUTO.ON	Automatic on	2.1.6.4
		---			Lock weight display	2.1.9
		----	o	OFF	Display on	2.1.9.1
		----		ON	Display off	2.1.9.2
		---			Bar graph mode	2.1.10
		----	o	NORMAL	Normal width	2.1.10.1
		----		WIDE	Extra wide	2.1.10.2

Continued on next page

Level 1	Level 2	Level 3	Active	Level 4	Function	CODE
<DEVICE>	INTERF.					2.2
	---	PROT.			Data transfer protocol	2.2.1
		----	o	SBI	SBI protocol	2.2.1.1
		----		XBPI	XBPI protocol	2.2.1.2
	---	BAUD			Baud rate	2.2.2
		----		600	600 baud	2.2.2.3
		----		1200	1200 baud	2.2.2.4
		----	o	2400	2400 baud	2.2.2.5
		----		4800	4800 baud	2.2.2.6
		----		9600	9600 baud	2.2.2.7
		----		19200	19200 baud	2.2.2.8
		----		38400	38400 baud	2.2.2.9
		----		57600	57600 baud	2.2.2.10
	---	PARITY			Parity bit	2.2.3
		----	o	ODD	Odd	2.2.3.3
		----		EVEN	Even	2.2.3.4
		----		NONE	No parity check	2.2.3.5
	---	STOPBT.			Number of stop bits	2.2.4
		----	o	1 BIT		2.2.4.1
		----		2 BITS		2.2.4.2
	---	HANDSH.			Type of handshake	2.2.5
		----		SOFTW.	Software handshake (X-On/X-Off)	2.2.5.1
		----		HARDW.	Hardware handshake (RTS/CTS)	2.2.5.2
		----	o	NONE	No handshake	2.2.5.3
	---	DATA BT.			Number of data bits	2.2.6
		----	o	7 BITS	7 data bits	2.2.6.1
		----		8 BITS	8 data bits	2.2.6.2
COMMUN.					Communication parameters	3.
	----	SBI			SBI communication parameter	3.1
	---	MAN.AUT.			Output	3.1.1
		----		MAN.W/O	Print individual value without stability	3.1.1.1
		----		MAN.W/	Print individual value after stability	3.1.1.2
		----	o	AUT.W/O	Print automatically without stability	3.1.1.4
		----		AUT.W/	Print automatically after stability	3.1.1.5
	---	CANCEL			Cancel automatic output	3.1.2
		----	o	OFF	Cancellation not possible	3.1.2.1
		----		ON	Cancel by pressing Print key	3.1.2.2
	---	FORMAT				3.1.3
		----	o	16 CHR.		3.1.3.1
		----		22 CHR.		3.1.3.2

Continued on next page

Level 1	Level 2	Level 3	Active	Level 4	Function	CODE
INPUT						4.
	-----	PASSWD.			Password	4.1.
		-----			Change/enter password	4.1.1
INFO					Information	5.
	-----	VER.NO.			Version number (firmware)	5.1
	-----	SER.NO.			Serial number	5.2
	-----	MODEL			Model designation	5.3
	-----	TYPE			Name/type information	5.4
	-----	INTRO			Intro text (if available)	5.5
LANG.					Language selection	6.
	-----	D			German	6.1
	-----	UK/US	o		English	6.2
	-----	F			French	6.4
	-----	I			Italian	6.5
	-----	E			Spanish	6.6
	-----	NL			Dutch	6.7
	-----	P/BR			Portuguese	6.8
	-----	PL			Polish	6.9
	-----	TR			Turkish	6.10
	-----	PYC			Russian/Cyrillic	6.11
	-----	SLO			Slovenian	6.12
	-----	SRB			Serbian	6.13
	-----	CODES			Number codes	6.25

4 Installation

4.1 Unpacking and Equipment Supplied

- ▶ Open the packaging, making sure to remove all parts carefully.
- ▶ After unpacking the device, check it immediately for any external damage.
- ▶ If you detect any damage, proceed as directed in Chapter "7 Care and Maintenance," page 33.
- ▶ Save the box and all parts of the packaging for any future transport. All cables should be unplugged when transporting.

The following parts are included in the equipment supplied:

Model Name	PMA.Evolution	PMA.HD
Large weighing pan: Ø 233 mm	x	–
Small weighing pan: Ø 180 mm	–	x
USB cable	x	x
Ex-link converter	x	x
Potential equalization cable	x	x
Link cable from converter to scale	x	x
Installation instructions	x	x

4.2 Selecting a Setup Location

Select the right setup location:

- Set up the device on a stable, even surface that is not exposed to vibrations.
- Maintain free access to the device at all times.

Choose a location that is not subject to the following negative influences:

- Heat (heater or direct sunlight)
- Drafts from open windows, AC systems, and doors
- Extreme vibrations during weighing
- Heavy "traffic areas" (personnel)

Acclimatization

Condensation from humidity can form on the surfaces of a cold device when it is brought into a warm area. You should therefore let a device that has been disconnected from its power source acclimatize for approximately 2 hours before reconnecting it to the supply voltage.

M

Seal on Scales Verified for Use in Legal Metrology:

Legislation requires that a seal be affixed to verified scales. On Sartorius devices, this seal takes the form of a sticker with the "Sartorius" logo. If the seal is removed, the validity of verification will become void and you must have your scale re-verified. The verification supplied here is for verified weighing instruments for use in the EEA. Please keep it in a safe place.

4.3 Installing the Scale



The scale must be disconnected from the power supply for all assembly work.

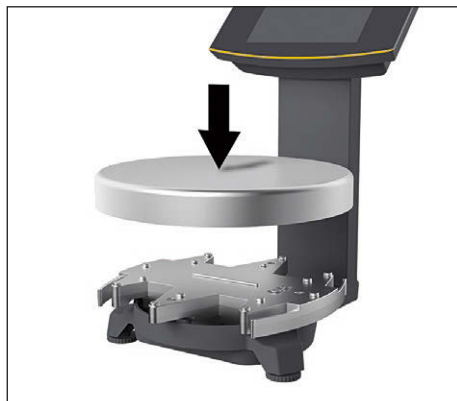

Placing the Weighing Pan onto the Scale

- ▶ Place the weighing pan onto the scale from above.

4.4 Supply Voltage

The scale is connected to the power supply via a PC/notebook or using the optional AC adapter YEPS01-USB (see Chapter "13 Accessories," page 41), which is supplied with mains adapters for use in various countries.

Power supply via the AC adapter is only required:

- When no PC or notebook is available.
- In exceptional cases, when the output power of the USB interface of the PC or notebook is not sufficient.

The assembly is described in the following.

4.4.1 Power Supply Assembly

If using a power supply, it will need to be assembled.



Using the wrong mains adapter may cause a fatal electric shock and damage the equipment.

Never plug the mains adapter into the socket when it is disconnected from the AC adapter (danger of electric shock).

- ▶ Select the correct mains adapter for your mains power supply. The mains adapter must be suitable for use with the wall outlet at the installation site.

Mains adapter sets

Bag	Region/country
YEPS01-PS1	<ul style="list-style-type: none"> – USA and Japan (US+JP) – Europe (EU) – United Kingdom (GB)
YEPS01-PS6	<ul style="list-style-type: none"> – Argentina (AR) – Brazil (BR) – Australia (AU) – South Africa (ZA)
YEPS01-PS7	<ul style="list-style-type: none"> – China (CN) – India (IN) – Korea (KR)

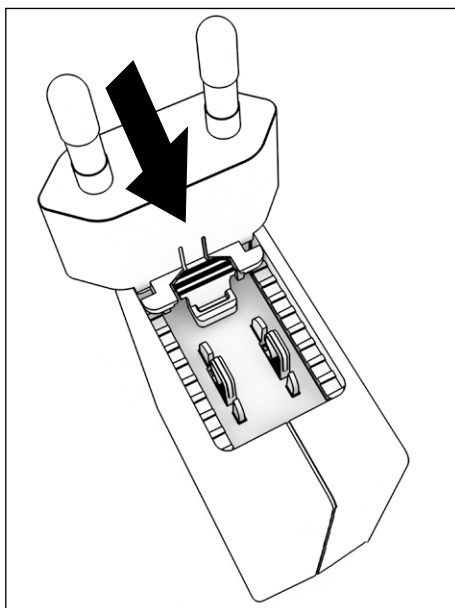

- ▶ Insert the power plug adapter into the power supply. The grooved button must be facing upwards.
- ▶ Push the power plug adapter as far as you can until it clicks into place.
- ▶ Check whether the power plug adapter is securely locked in place by pulling it gently.
- ▶ Wenn sich der Netzsteckeradapter nicht verschieben lässt: Der Netzsteckeradapter ist verriegelt.

Removing/Replacing the Mains Adapter

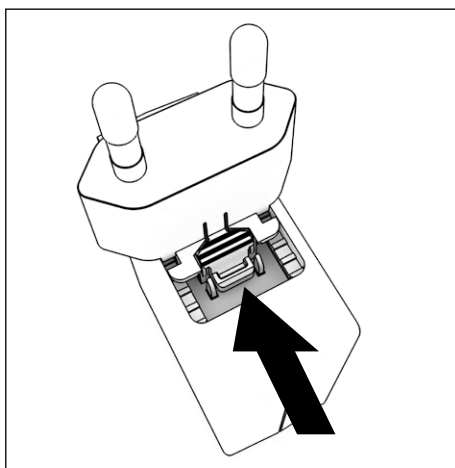

- ▶ Press the grooved button from above and pull back on the mains adapter.
- ▶ Push the power plug adapter out of the power supply and remove it.

Power Connection/Safety Precautions

- Only use original Sartorius AC adapters.
The AC adapter has an IP rating of IP40 in accordance with EN60529 / IEC60529.
- Make sure that the voltage rating printed on this unit matches the voltage at the place of installation.
- If the stated supply voltage or the plug design of the AC adapter does not comply with your country's standard then please inform your nearest Sartorius representative.
- The power must be connected in accordance with the regulations applicable in your country.

4.4.2 Connecting the Scale

Connecting the Scale

- ▶ Insert the link cable plug into the RJ-45 socket on the back of the display.



Laying the Link Cable

- ▶ Lay the link cable (blue) through the cable holders on the back of the scale.



- ▶ Connect the link cable to the ex-link converter.



Connecting the Grounding Cable

This explosion-protected system should be set up according to commonly accepted technical standards. The applicable national electrical code and safety regulations for your particular country must be observed.

Before commissioning the scale, a check must be carried out by or under the supervision of a qualified electrician to ensure that the system is in good working order.

Check whether or not the competent authorities (e.g., industrial supervisory board) need to be informed. It is also necessary to carry out inspections of the system during operation.

Inspection intervals should be such that any significant defects that may occur can be identified in good time. Inspections should be carried out at least once every three years. The applicable requirements and guidelines should also be observed during operation.

Establish a low-resistance connection from the scale and the ex-link converter YCO14-Z to a customer-supplied equipotential bonding conductor connection via the equipotential bonding conductor connections (PA) on the device using a suitable grounding cable with a gage of at least 4 mm².

Installation must be carried out properly by trained personnel and according to commonly accepted technical standards. The system should only be operated for the first time when it is certain that the area is not potentially explosive.

If deviations are evident during startup due to transport damage (e.g., no display, no backlighting), disconnect the scale from the power supply and contact Sartorius Service.

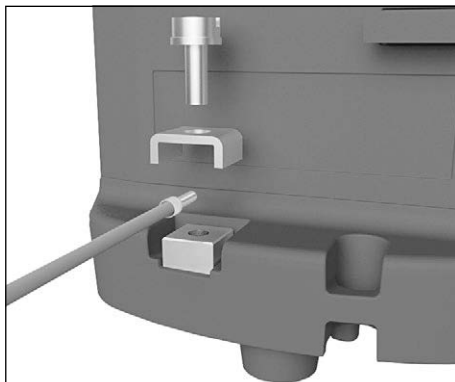

Connect the scale to the equipotential bonding conductor using an equipotential bonding cable with a gage of at least 4 mm².

- ▶ Connect the cable lug of the equipotential bonding cable to the grounding terminal of the scale.
- ▶ Connect the equipotential bonding cable to the customer-supplied equipotential bonding conductor.

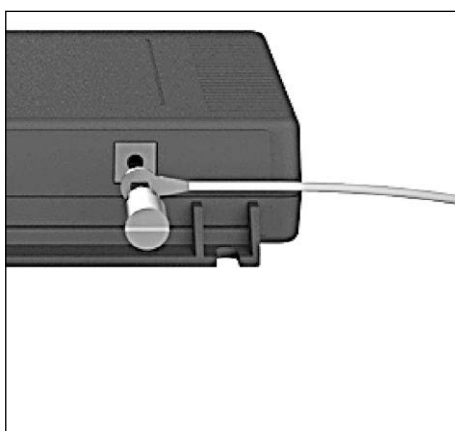

Connect the ex-link converter to the equipotential bonding conductor using another equipotential bonding cable with a gage of at least 4 mm².

- ▶ Connect the cable lug of the equipotential bonding cable to the grounding terminal of the ex-link converter.
- ▶ Connect the equipotential bonding cable to the customer-supplied equipotential bonding conductor.

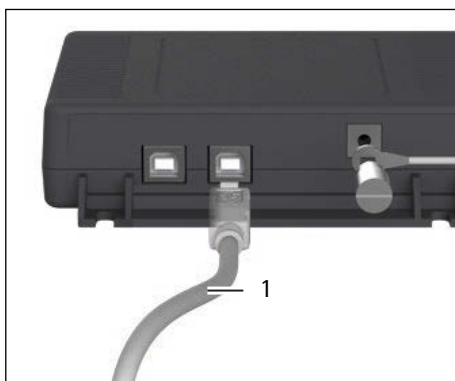

Connecting a PC/Notebook

- ▶ Insert a USB cable (1) into the right-hand socket on the ex-link converter and connect the cable to a PC or notebook. If the ex-link converter YCO-Y is being used and installed in Zone 2 or Division 2 potentially explosive areas and the USB cable (1) does not have an intrinsically safe electrical circuit, the cable must be secured against disconnection. Refer to the Control Drawing and Safety Instructions (Chapter 15, page 42) as well as the following illustrations.

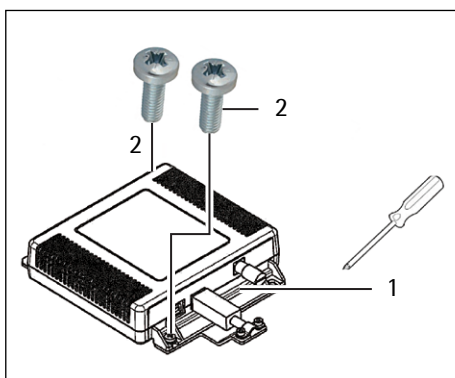

- ▶ Fasten the strain relief YSR01 to the converter (1) using the two screws (2).

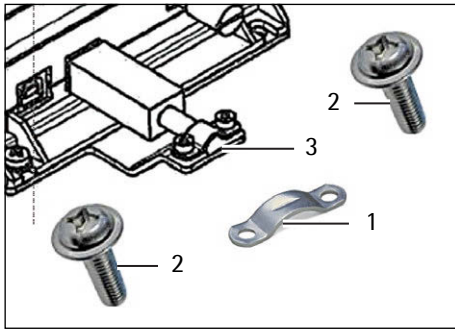

- ▶ Attach the USB cable to the strain relief (3) using the clamp (1) and the two screws (2).

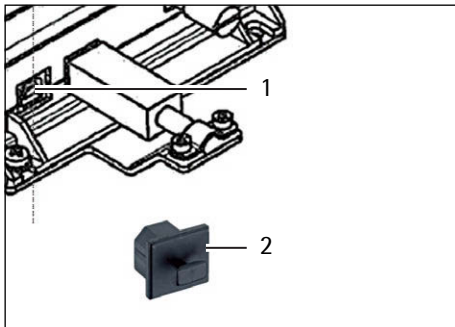

- ▶ Use the protective cap (2) to seal up the left-hand USB port (1).

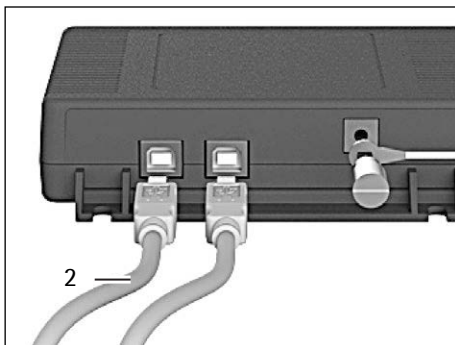

Connecting the AC Adapter (Optional); not for YC014-Y when Installed in Zone 2 or Division 2 Potentially Explosive Areas

- ▶ Insert an additional USB cable (2) into the ex-link converter.

- ▶ Insert the USB cable into the YEPS01-USB AC adapter.
- ▶ Plug the AC adapter into a wall outlet (supply voltage).

4.5 Anti-theft Locking Device

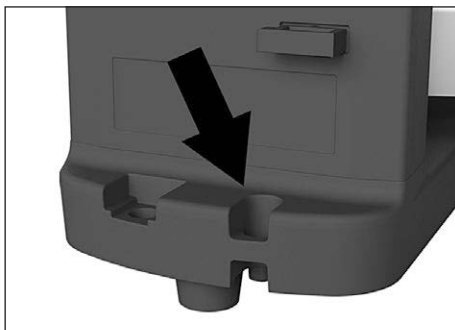

- ▶ If required, secure the scale at the back.

5 Commissioning

5.1 Leveling

Leveling for PMA.HD and Verified Models

Leveling the scale compensates for slant or unevenness at the place of installation. The scale must be perfectly horizontal to ensure consistent, reproducible weighing results.

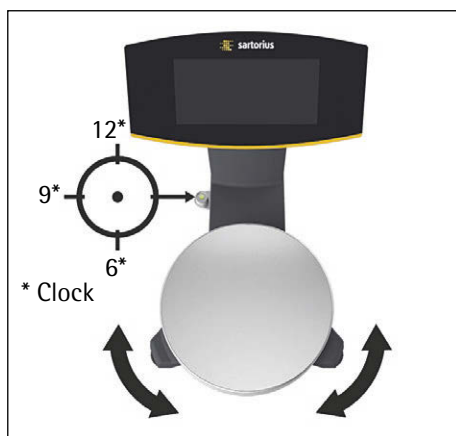

The scale needs to be re-leveled and then adjusted each time its setup location is changed.

- ▶ Turn the two leveling feet as shown in the illustration until the air bubble is centered within the circle of the level indicator.
 - Air bubble at "12 o'clock:" Turn both feet clockwise.
 - Air bubble at "3 o'clock:" Turn the left foot clockwise and the right foot counterclockwise.
 - Air bubble at "6 o'clock:" Turn both feet counterclockwise.
 - Air bubble at "9 o'clock:" Turn the left foot counterclockwise and the right foot clockwise.

5.2 Warm-up Time

To ensure accurate results are delivered, the scale must warm up for at least 30 minutes after initial connection to the power supply. Only then will the device have reached the required operating temperature.

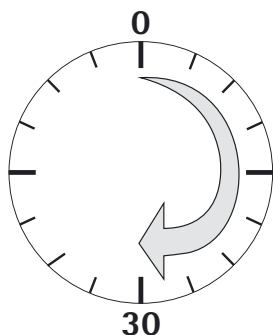

M

Using a Scale Verified for Use in Legal Metrology:

- Ensure that there is a warm-up time of at least 24 hours after initial connection to the power supply.

6 Operation

6.1 Switching the Device On/Off

Switching On



- ▶ Briefly press the  key (on/standby).
- ▷ An automatic self-test runs. This ends when the display shows 0.0 g.
- ▶ If another value is displayed: Set the scale to zero via the **·0|T·** key.

Switching Off

- ▶ Press and hold the  key for several seconds (on/standby).
- ▷ The scale switches to standby mode.

6.2 Locking the Keypad/Weight Display

Locking

- ▶ Briefly press the  key (on/standby) to lock the keypad and turn off the weight display.
- ▷ The padlock symbol  flashes for several seconds.
- ▶ Press the padlock symbol  while flashing to activate the lock.
- ▷ The keypad/weight display is locked and the padlock symbol lights up continually.

Unlocking

- ▶ Press the padlock symbol  to deactivate the lock.
- ▶ Enter the password (if set) (see Chapter 6.7.2.6, page 31).
- ▷ The lock is deactivated.

6.3 Zeroing/Taring

- ▶ Briefly press the **·0|T·** key.

6.4 Calibration/Adjustment



The scale needs to be re-leveled and then adjusted each time its setup location is changed.

Warm-up Time

To ensure accurate results are delivered, the scale must warm up for at least 30 minutes after initial connection to the power supply. Only then will the device have reached the required operating temperature.

- ▶ Wait approx. 30 minutes after connecting the scale to the power supply before adjusting the scale and weighing.

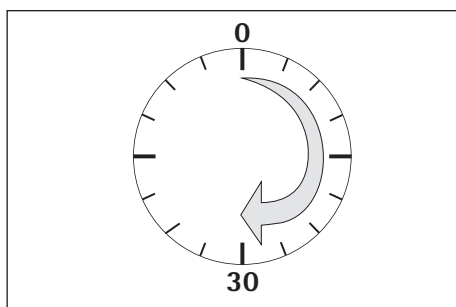

Using a Scale Verified for Use in Legal Metrology:

- Ensure that there is a warm-up time of at least 24 hours after initial connection to the power supply.

6.4.1 Calibration

External Calibration/Adjustment for Verified Scales

Scales for use in legal metrology must be externally calibrated before being verified at the location of use.

- When the scale is used in legal metrology, external calibration is locked as follows:
 - The menu access switch is locked
 - The menu access switch cap is sealed
- ▶ Press the **0|T** key for approx. 2 seconds.
- ▷ The preset calibration weight appears in the display (e.g., 5000 g)
- ▶ If required, select a different calibration weight via the **▲**/**▼** keys.
- ▶ Confirm the displayed calibration weight via the **OK** key.
- ▷ **CAL.EXT.** appears on the display with the negative calibration weight.
- ▶ Center the calibration weight on the weighing pan.
- ▷ The calibration is performed. The calibration is complete when **CAL.DON** appears in the display.
- ▶ Remove the calibration weight from the weighing pan.

6.5 Weighing

M

Using a Verified Balance in Legal Metrology:

The Type-Approval Certificate for verified scales is only valid for non-automatic weighing instruments. For automatic operation with or without additional integrated equipment, please follow the applicable national regulations for the installation location.

- The temperature range (°C) listed on the ID label should not be exceeded during operation.

Example:

Ⓜ +10–+30°C

6.5.1 Weighing with One Decimal Place

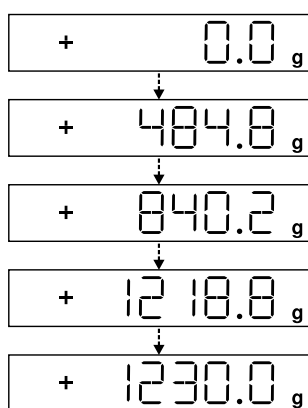

- ▶ Place the empty paint can on the weighing pan.
- ▶ Briefly press the **0|T** key to zero.
- ▷ The display shows "0.0 g."
- ▶ Add the first component "484.8 g."
- ▶ Read off the weight when the stability symbol (in this example) "g" is displayed.
- ▶ Add the other components until the desired weight (formula) is reached.
- ▶ Remove the filled paint can from the weighing pan.



Danger of Scale Damage!

Never close a paint can using a hammer while it is still on the weighing pan.

- ▶ When closing the paint can, place it on a firm, stable surface.

6.5.2 Weighing with Two Decimal Places (Not for Verified Models)



A menu setting is required for weighing with two decimal places (see Chapter "6.7.2.4 Activating the Toggle Key (Not for Verified Models)," page 30).



- ▶ Place the empty paint can on the weighing pan.
- ▶ Briefly press the **0|T** key to zero.

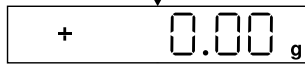

- ▷ The display shows "0.0 g."
- ▶ Press the toggle key **↔**.
- ▷ The display shows "0.00 g."

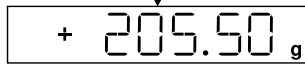

- ▶ Add the first component "205.50 g."
- ▶ Read off the weight when the stability symbol (in this example) "g" is displayed.

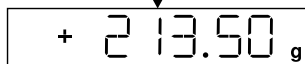

- ▶ Add the other components until the desired weight (formula) is reached.

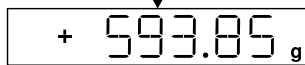

- ▶ Remove the filled paint can from the weighing pan.

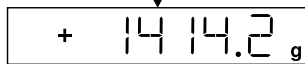

When the scale is tared and the second decimal place with a resolution of 0.05 g is activated via the toggle key **↔**, weighing up to 999.95 g with two decimal places can be performed.

Values over 999.95 g can only be weighed using one decimal place.



Danger of Scale Damage!

Never close a paint can using a hammer while it is still on the weighing pan.

- ▶ When closing the paint can, place it on a firm, stable surface.

6.6 Applications



Note for Scales for Use in Legal Metrology:

All application programs can be selected on scales verified for use in legal metrology. Computed values can be marked using the following characters:

- Percent = %
- Computed values = o, **◇** symbol

6.6.1 Calculation by a Factor

This function enables you to weigh in amounts that are smaller or larger than that of your basic formula for a specific paint color (e.g., 250 ml of a 1 l formula).

The factors (amounts) can be set via the factor key **↵** and **▲/▼** in a range of 0.1 to 6.0.

The following factors can be set directly via the factor key **↵**:

0.25 0.5 0.75 1.0 1.5 2.0 2.5 3.0 3.5 4.0 4.5 5.0.

Using the keys **▲** (up) and **▼** (down), the factor can be changed

- in the range 0.10 to 1.0 in increments of 0.01
- in the range 1.0 to 6.0 in increments of 0.1

Factor Calculation Example

As you add the components of your formula, the weight is displayed in "g."

M

For models verified for use in legal metrology, the displayed value is marked with a \diamond symbol to indicate computed values.

Suppose you want to weigh 250 ml for a basic formula that has a total of 1 l, and you don't want to have to manually recalculate the individual components of the formula.

The basic formula for 1 liter:

	250 g	1st component
+	250 g	2nd component
+	500 g	3rd component
Total:	1000 g	

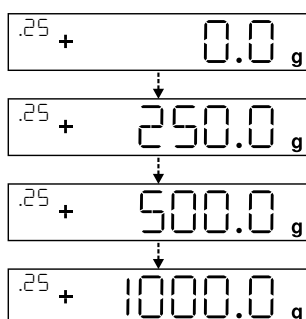

- ▶ Place the empty container on the weighing pan.
- ▶ Briefly press the $\cdot 0|T \cdot$ key to tare.
- ▶ Press the factor key $\boxed{.25}$ several times until the factor ".25" is displayed below the factor key.
- ▶ Slowly add the first component "250 g" of the formula until the display shows "250 g."
- ▶ Add the second color component "250 g" until the display shows "500 g."
- ▶ Add the third component "500 g" until the display shows "1000 g."

This concludes the calculation example. According to the display, exactly 1000 g was poured in, but the container actually only contains 250 g by weight in accordance with the factor you selected.

The procedure is the same for any other conversion factor.

6.6.2 Weighing Using the Recalculation Function

Let's suppose that you poured in too much of one color component for a given formula (in this example, a 4-component recipe).

This example further assumes that you previously poured in all of the other amounts exactly according to each of the values you entered and saved them by pressing the MEM key \boxed{OK} .

- ▶ Press the $\boxed{\downarrow}$ key to start the recalculation program.
- ▶ "C" flashes on the display.
- ▶ Correct the value using the $\boxed{\uparrow}$ / $\boxed{\downarrow}$ keys to match the specified formula value.
- ▶ Press the MEM key \boxed{OK} .
- ▶ The scale automatically calculates the amount to be added for each of the components that were already poured in. The display shows the amounts required to correct the formula up to the point at which the overpour occurred.
- ▶ After the correction has been completed, you can continue filling the remaining components.

i

You can correct overpours as often as needed, as long as the total weight of the formula does not exceed the scale's maximum weight.

Keep in mind that the total quantity of paint (liter) at the conclusion of filling increases each time you correct a component. Press the \boxed{C} key to display the correction factor of the fill quantity. "C" = correction factor

Recalculation Example (Gross Weight)



For models verified for use in legal metrology, the displayed value is marked with a \diamond symbol to indicate computed values.

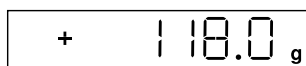

- ▶ Place the empty container on the weighing pan.
- ▷ The scale shows the weight of the empty paint can.
- ▶ Briefly press the $\cdot 0|T$ key to tare.

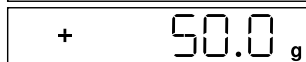

- ▶ Slowly add the first component (50 g) of the formula until the display shows "50 g."

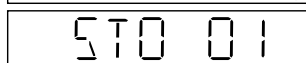

- ▶ Briefly press the \square key to save the value.

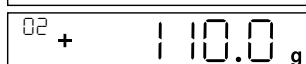

- ▷ "STO 01" appears on the display, the first value is saved.



- ▷ "02" appears in the top left of the display (second color component).

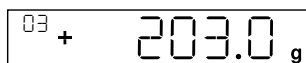

- ▶ Add the second color component (60 g) until the display shows "110 g."

- ▶ Briefly press the \square key to save the value.

- ▷ "STO 02" appears on the display, the second value is saved.

- ▷ "03" appears in the top left of the display (third color component).

- ▶ Add the third color component (90 g) until the display shows "200 g."

Oops! You poured in too much (203 g). The correct value for the formula is 200.0 g.

- ▶ Press the \surd key.

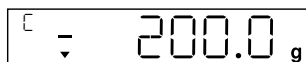

- ▷ The recalculation is started. "C" flashes in the top left of the display.

- ▶ Press the \surd key until the correct weight value "200 g" is displayed.

- ▶ Briefly press the \square key to confirm the corrected value.

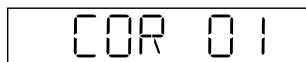

- ▷ "COR 01" flashes briefly on the display (correction of the first color component).

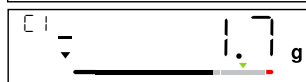

- ▷ "C1" appears in the top left of the display with the weight value to be corrected "- 1.7 g."



- ▶ Add 1.7 g of the first color component until the display shows "0.0 g" or the bar graph stops below the green arrow.

- ▶ Confirm the correction for the first color component by pressing the \square key.

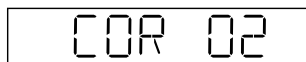

- ▷ "COR 02" flashes briefly on the display (correction of the second color component).

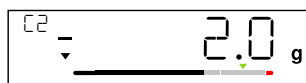

- ▷ "C2" appears in the top left of the display with the weight value to be corrected "- 2.0 g."



- ▶ Add 2.0 g of the second color component until the display shows "0.0 g" or the bar graph stops below the green arrow.

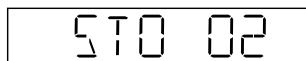

- ▷ "STO 02" appears on the display, the second (corrected) value is saved.

- ▷ You are automatically returned to the formulation program.



- ▷ "04" appears in the top left of the display (fourth color component).

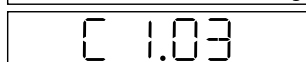

- ▶ Press the \square key to check the amount of the total weight.

- ▷ The correction factor "C 1.03" appears on the display for several seconds.

Total weight = weight of specified formula x correction factor.



- ▷ "04" appears again in the top left of the display after the correction factor is displayed (fourth color component).

- ▶ Add additional color components of the formula as described above.

This concludes the calculation example.

6.7 Menu Settings

6.7.1 Accessing the SETUP Menu

Accessing the SETUP menu and settings is described in the following using "Adapting the scale to ambient conditions" as an example (SETUP -> SCALE -> AMBIEN.):

- ▶ Press the **OK** key for approx. 2 seconds.
- ▷ Level 1 of the SETUP menu is displayed.
- ▶ Select the **SETUP** menu item of the first level using the **▲**/**▼** keys.
- ▶ Press the **OK** key.
- ▷ Level 2 of the SETUP menu is displayed.
- ▶ Select the **SCALE** menu item of the second level using the **▲**/**▼** keys.
- ▶ Press the **OK** key.
- ▷ Level 3 of the SETUP menu is displayed.
- ▶ Select the **AMBIEN.** menu item of the third level using the **▲**/**▼** keys.
- ▶ Press the **OK** key.
- ▷ Level 4 of the SETUP menu is displayed.
- ▶ Select the desired setting using the **▲**/**▼** keys.
- ▶ Press the **OK** key.
- ▷ The setting is applied; "o" appears on the display.
(This concludes the example.)
- ▶ Press the **C** key several times to exit the menu.



A detailed list of possible settings can be found in Chapter "3.5 Menu List," page 13.

6.7.2 Configuring the Main Menu Settings

6.7.2.1 Accessing the Setup Menu

- ▶ Press and hold the **OK** key for approx. 2 sec.
- ▷ **SETUP** (level 1) appears on the display.

6.7.2.2 Language Setting

Level 1 Level 2

LANG.		▶ Press \uparrow , select LANG.
		▶ Press OK
D	o German	▶ Press \uparrow/\downarrow , select language
UK/US	English	▶ Press OK , "o" appears.
F	French	▶ The desired setting is applied.
I	Italian	▶ Press C several times to exit the menu
etc.		

6.7.2.3 Standard Default Settings (0.1 g)/Polyrange (0.05 g/0.1 g) and Grams/Parts per Pound. (Not for Verified Models)

The default settings which are active when the scale is switched on can be found under "SETUP > SCALE > WT.UNIT" and "SETUP > SCALE > DSP.DEC.:"

▶ Access the Setup menu (see Chapter 6.7.2.1, page 29).

Level 1 Level 2 Level 3 Level 4

SETUP			▶ Press OK
--- SCALE			▶ Press OK
--- WT.UNIT	Units		▶ Press \uparrow/\downarrow , e.g., select DSP.DEC.
	--- o GRAMS		▶ Press OK
	--- PT.P.LB		▶ Press \uparrow/\downarrow , e.g., select ALL
--- DSP.DEC.	Accuracy		▶ Press OK , "o" appears
	--- o ALL		▶ The new code is set.
	--- POLYR.		▶ Press C several times to exit the menu

6.7.2.4 Activating the Toggle Key (Not for Verified Models)

When the toggle key S is active, you can use it to toggle the unit between, e.g., grams, parts per pound, or the decimal place. The unit and/or decimal place is toggled when the key is pressed:

▶ Access the Setup menu (see Chapter 6.7.2.1, page 29).

Level 1 Level 2 Level 3 Level 4

SETUP			▶ Press OK
--- APP.PRG.			▶ Press \uparrow/\downarrow , select APP.PRG.
--- TOGGLE			▶ Press OK
	--- o ON		▶ Press \uparrow/\downarrow , select ON
	--- OFF		▶ Press OK , "o" appears.
			▶ Toggle key S is activated.
			▶ Press C several times to exit the menu

Configuring the Toggle Key S Function

Pressing the toggle key S toggles the scale between the default settings (see Chapter 6.7.2.3, page 30) and settings defined in "SETUP > APP.PRG. > UNIT" and "SETUP > APP.PRG. > DSP.DEC."

▶ Access the Setup menu (see Chapter 6.7.2.1, page 29).

Level 1	Level 2	Level 3	Level 4
SETUP			▶ Press OK
	--- APP.PRG.		▶ Press ▲ / ▼ , select APP.PRG.
		--- UNIT 2	▶ Press OK , press ▲ / ▼ , select UNIT 2
		--- o GRAMS	▶ Press OK , press ▲ / ▼ , select setting (e.g., GRAMS)
		--- PT.P.LB	▶ Press OK , "o" appears indicating the desired setting is applied.
		--- DEC 2	▶ Press C
		--- ALL	▶ Press ▲ / ▼ , select DEC 2
		--- o POLYR.	▶ Press OK , press ▲ / ▼ , select setting
			▶ Press OK , "o" appears indicating the desired setting is applied.
			▶ Press C several times to exit the menu

6.7.2.5 Activating the "LOCK" Function

The "LOCK" function protects the scale from unauthorized use. When this function is active, the scale readout shows weight values only when there is active communication between the scale and a connected PC. If communication is interrupted, the readout goes blank and the display shows a padlock symbol. Activation of the LOCK function is configured under "EXTRAS."

- ▶ Access the Setup menu (see Chapter 6.7.2.1, page 29).

Level 1	Level 2	Level 3	Level 4
DEVICE			▶ Press ▲ / ▼ , select DEVICE, press OK
	--- EXTRAS		▶ Press ▲ / ▼ , select EXTRAS, press OK
		--- LOCK	▶ Press ▲ / ▼ , select LOCK, press OK
		--- o ON	▶ Press ▲ / ▼ , select ON
		--- OFF	▶ Press OK , "o" appears,
			▶ The "LOCK" function  is activated.
			▶ Press C several times to exit the menu

6.7.2.6 Password Prompt

In addition to the "LOCK" function, you can also configure password protection for additional security. With this feature, the "LOCK" function can only be deactivated by entering the password you configure.

Entering the Password

When the password prompt appears, the numbers 1 2 3 4 5 6 appear on the display. You can switch to the numbers 7 8 9 0 and back again via the **▲**/**▼** keys.

- ▶ Enter the password by entering the individual numbers on the display.
- ▶ When you enter the correct password, the "LOCK" function will be deactivated.

Changing the Password

The password is numeric and can have up to 6 digits. Entering 6 spaces deletes the password, which deactivates the password function. This restores the device to its original setting (scale is not password-protected).

► Access the Setup menu (see Chapter 6.7.2.1, page 29).

Level 1 Level 2 Level 3

<pre>INPUT --- PASSWD.</pre>	<ul style="list-style-type: none"> ► Press ▲/▼, select INPUT, press OK
<pre> --- OLD PW</pre>	<ul style="list-style-type: none"> ► Press ▲/▼, select PASSWD., press OK
<pre> ---</pre>	<ul style="list-style-type: none"> ▷ When an old password is active, OLD PW appears briefly so that you can enter the old password.
<pre> ---</pre>	<ul style="list-style-type: none"> ▷ The display shows: "-----."
<pre> ---</pre>	<ul style="list-style-type: none"> ▷ The first line flashes.
<pre> ---</pre>	<ul style="list-style-type: none"> ► Make the following inputs:
<pre> ---</pre>	<ul style="list-style-type: none"> - ▲/▼ keys: Selects numbers 0 to 9.
<pre> ---</pre>	<ul style="list-style-type: none"> - C: Go back to the previous number.
<pre> ---</pre>	<ul style="list-style-type: none"> - OK: Confirm entry or go to the next number.
<pre> ---</pre>	<ul style="list-style-type: none"> ► Repeat to enter the remaining numbers.
<pre> ---</pre>	<ul style="list-style-type: none"> ▷ If you make an incorrect entry, NOT OK appears. Press OK and reenter the old password.
<pre> ---</pre>	<ul style="list-style-type: none"> NEW PW
<pre> ---</pre>	<ul style="list-style-type: none"> ▷ When you make a correct entry, NEW PW appears briefly so that you can enter the new password.
<pre> ---</pre>	<ul style="list-style-type: none"> ▷ The display shows: "-----."
<pre> ---</pre>	<ul style="list-style-type: none"> ▷ The first line flashes.
<pre> ---</pre>	<ul style="list-style-type: none"> ► Make the following inputs:
<pre> ---</pre>	<ul style="list-style-type: none"> - ▲/▼ keys: Selects numbers 0 to 9.
<pre> ---</pre>	<ul style="list-style-type: none"> - C: Go back to the previous number.
<pre> ---</pre>	<ul style="list-style-type: none"> - You can enter spaces to delete the number/password.
<pre> ---</pre>	<ul style="list-style-type: none"> - OK: Confirm entry or go to the next number.
<pre> ---</pre>	<ul style="list-style-type: none"> ► Repeat to enter the remaining numbers.
<pre> ---</pre>	<ul style="list-style-type: none"> ▷ The password has been changed.
<pre> ---</pre>	<ul style="list-style-type: none"> ► Press C several times to exit the menu.

6.7.2.7 Resetting the Scale: "RESET"

If required, you can restore the scale to its factory settings.

Note:

If you have activated the password function, this feature is password-protected.

► Access the Setup menu (see Chapter 6.7.2.1, page 29).

Level 1 Level 2 Level 3 Level 4

<pre>SETUP</pre>	<ul style="list-style-type: none"> ► Press ▲/▼, select SETUP, press OK
<pre> --- GEN.SRV.</pre>	<ul style="list-style-type: none"> ► Press ▲/▼, select GEN.SRV., press OK
<pre> --- MEN.RES.</pre>	<ul style="list-style-type: none"> ► Press ▲/▼, select MEN.RES., press OK
<pre> --- DEF.AUL.</pre>	<ul style="list-style-type: none"> ► Press ▲/▼, select DEF.AUL.
<pre> --- o NO</pre>	<ul style="list-style-type: none"> ► Press OK, "o" appears,
	<ul style="list-style-type: none"> ▷ The factory settings are loaded.
	<ul style="list-style-type: none"> ► Press C several times to exit the menu

7 Care and Maintenance

7.1 Cleaning



Electrical Hazard from Voltage or Current

Disconnect the AC adapter (if connected) from the mains. Unplug any connected data cables from the ex-link converter. Never open the scale, the AC adapter, or the ex-link converter. The parts contained in these cannot be cleaned, repaired or replaced by the user.

- Make sure that no liquid or dust gets into the scale, the AC adapter, or the ex-link converter.
- Only use soft brushes and cloths for cleaning.
- Never use cleaning accessories or agents that contain abrasive components or ingredients (e.g., scouring cream, steel wool), which can ultimately damage the equipment.



Do not clean the following parts with acetone or aggressive cleaning agents: mains socket, data interface, labels, and all other plastic parts.

Cleaning the Control Panel

- ▶ Turn off the device before cleaning the control panel since touching the screen could trigger unwanted inputs.

Cleaning the Device Housing

- ▶ Clean the device.
- ▶ Use a soft cloth to dry the device.

7.2 Maintenance



Electrical Hazard from Voltage or Current

Repair work on the (optional) AC adapter must only be carried out by trained service technicians. Contact Sartorius Service for professional repairs (see Chapter 15.1, page 42).

To ensure the continued accuracy of your scale, we recommend scheduling regular servicing at least once a year.

Sartorius Service offers different service contracts with maintenance intervals that are tailored to your needs.

A calibration certificate should always be issued as part of every maintenance session.

Safety inspections of the AC adapter and its connections must be performed at appropriate intervals by a qualified electrician (e.g., every 2 years).

8 Malfunctions

Problem	Cause	Remedy
No segments appear on the weight display	<ul style="list-style-type: none"> – No AC power is available 	<ul style="list-style-type: none"> – Check power supply
The weight readout shows "LOW"	<ul style="list-style-type: none"> – No weighing pan on the scale 	<ul style="list-style-type: none"> – Position the weighing pan
The weight readout shows "HIGH"	<ul style="list-style-type: none"> – Weighing capacity exceeded 	<ul style="list-style-type: none"> – Unload the scale
The weight readout changes constantly	<ul style="list-style-type: none"> – Unstable ambient conditions – Excessive vibration or draft – Weighing pan is being affected at some point by outside influences 	<ul style="list-style-type: none"> – Set up scale in another area – Adjust the scale settings (see Chapter "3.5 Menu List," page 13)
The weight readout is obviously incorrect	<ul style="list-style-type: none"> – The sample is not stable – Scale not tared before weighing 	<ul style="list-style-type: none"> – Tare before weighing
No weight value is shown and the padlock symbol  is displayed	<ul style="list-style-type: none"> – PC connection to the scale has been interrupted, activating the "LOCK" function – Manual "LOCK" function is active 	<ul style="list-style-type: none"> – Access the scale operating menu to make the necessary adjustment and switch off the "LOCK" function – Check the connection – Switch off the manual "LOCK" function

9 Storage

If the device is not set up immediately after delivery, or will not be used temporarily, the ambient conditions listed in Chapter "12 Technical Data," page 37 must be observed for storage.



Only store the device in dry buildings and do not leave the device outdoors.

In case of improper storage, no liability will be assumed for resulting damage.

10 Disposal

Packaging

The packaging consists of environmentally friendly materials that can be used as secondary raw materials. The packaging is to be taken to a local waste disposal site if no longer required.

Device



The device, including accessories and empty non-rechargeable and rechargeable batteries, does not belong in your regular household waste; this device is manufactured from high-grade materials which can be recycled and reused. European Directive 2002/96/EC (WEEE) requires that electrical and electronic equipment be separated from normal household waste so that it may then be recycled. The crossed-out waste bin symbol indicates that separate collection is required.

In Germany and several other countries, Sartorius itself assumes responsibility for the return and legally compliant disposal of its electrical and electronic products. These products may not be placed with household waste or be brought to collection centers run by local public disposal operations – not even by small commercial operators. Please contact Sartorius Service.

In countries that are not members of the European Economic Area (EEA) or where no Sartorius subsidiaries or dealerships are located, please contact your local authorities or a commercial disposal operator.

Prior to disposal and/or scrapping of the device, any batteries should be removed and disposed of at a local collection point.

Sartorius will not take back devices contaminated with hazardous materials (ABC contamination) – either for repair or disposal.

Addresses for Disposal

Detailed information with service addresses for the disposal of your device can be found on our website (www.sartorius.com).





11 Serial Number Coding

Sartorius Lab Instruments GmbH & Co. KG
 37070 Goettingen, Germany Made in Germany

产品型号: [REDACTED]

产品名称: 卓逸PMA [REDACTED]

0°C ≤ Ta ≤ +40°C

II 2G Ex ib IIB T4 Gb
 FM 14ATEX0085X
 IECEx FME 14.0008X
 PCEC CE16.2058X

CA: Ex ia IS CLI, Div 1, GP C,D T4
 Zone 1, Ex ib IIB T4
USA: IS CLI, Div 1, GP C,D T4
 CL I, Zone 1, AEx ib IIB T4



For installation and maintenance see control drawing 2021459. Pour installation et maintenance voir le No 2021459 du diagramme de contrôle.
 安装和维护请参见安全说明 2021459。 1000011682

The manufacture date of this device is encoded in the serial number. The format is as follows:

YMM x x x x	
Y	Year
3	2014-2020
4	2021-2027
5	2028-2034, etc.

The Y column indicates the year group, which covers a period of 7 years. Within each year group, the months (M M) are counted up from 13.

Year:	2015	2016	2017	2018	2019	...
MM:	25-36	37-48	49-60	61-72	73-84	...

Example:
 328xxxxx (April 2015). "xxxxx" is a consecutive number. Every month it starts with 1 and increases consecutively.

12 Technical Data

12.1 General Data

Specification	Unit	Value
Scale		
Supply voltage		Only via USB port or Sartorius AC adapter YEPS01-USB
Input voltage	V_{DC}	+4.5–5.0
Power consumption	W	2.0 (typically)
Further data		IP40 in accordance with EN 60529/IEC 60529
Ambient conditions		
The specifications apply under the following ambient conditions:		
Environment		For indoor use only
Ambient temperature*	°C	+10 to +30
Operational capability	°C	Guaranteed between +5 and +40
Storage and shipping	°C	-10 to +60
Relative humidity **	%	15 to 80 for temperatures up to 30°C non-condensing, decreasing linearly to 50% relative humidity at 40°C
Ex-link converter interface connection		USB, type B
Electromagnetic compatibility		In accordance with EN 61326-1/IEC 61326-1 Electrical equipment for measurement, control and laboratory use – EMC requirements – Part 1: General Requirements
Interference resistance		Basic requirements
Transient emissions		Class B Suitable for use in residential areas and areas that are connected to a low voltage network that also supplies residential buildings.
	M	Verified scales in accordance with EU requirements comply with the requirements of Council Directive 2014/31/EU with EN 45501:2015 and OIML R76:2006.
		* For verified scales in accordance with EU requirements, refer to the information on the scale. ** For verified scales in accordance with EU requirements, the legal regulations apply.
Available application programs		Recalculation, factor calculation, formula
Power supply YEPS01-USB		
USB power plug		Type FSP007-P01P (manufacturer's designation)
Primary		100 – 240 V~, ±10%, 50 – 60 Hz, ±5%, ≤ 0.2 A
Secondary		5.2 V_{DC} ± 5%, 1.4 A (max.)
Further data		Protection class II IP40 in accordance with EN 60529/IEC 60529
Ex-link converter YC014-Z, YC014-Y		
Further data		IP40 in accordance with EN 60529/IEC 60529

12.2 Model-specific Data

Specification	Unit	Value	Value
Model name		PMA.Evolution	PMA.HD
		EVO1X	LAB1X
Weighing capacity	g	7500/999.95	2200
Readability	g	0.1/0.05	0.01/0.1
Tare range (subtractive)	g	-7500	-2200
External adjustment weight / accuracy class	kg	1, 2, 5 / F2 or better	1, 2 / F1 or better
Size of weighing pan	∅ mm	233	180
Net weight	kg	2.4	2.3

12.3 Verified Models with EC Type Approval Certificate: Model-specific Technical Data

Specification	Unit	Value
Model name		PMA.Evolution EVO1X
Accuracy class		Ⓔ
Type		PMA-EV
Weighing capacity max.	g	7500
Scale interval d	g	0.1
Verification scale interval e	g	1
Temperature range		+10°C–+30°C
Tare equalization range (subtractive)		≤ 100% from max. weighing capacity

Specification	Unit	Value
Model name		PMA.HD, LAB1X
Accuracy class		Ⓕ
Type		PMA-HD
Weighing capacity max.	g	2200
Scale interval d	g	1
Verification scale interval e	g	1
Temperature range		+10°C–+40°C
Tare equalization range (subtractive)		≤ 100% from max. weighing capacity

12.4 Device Dimensions

12.4.1 Model EVO1X

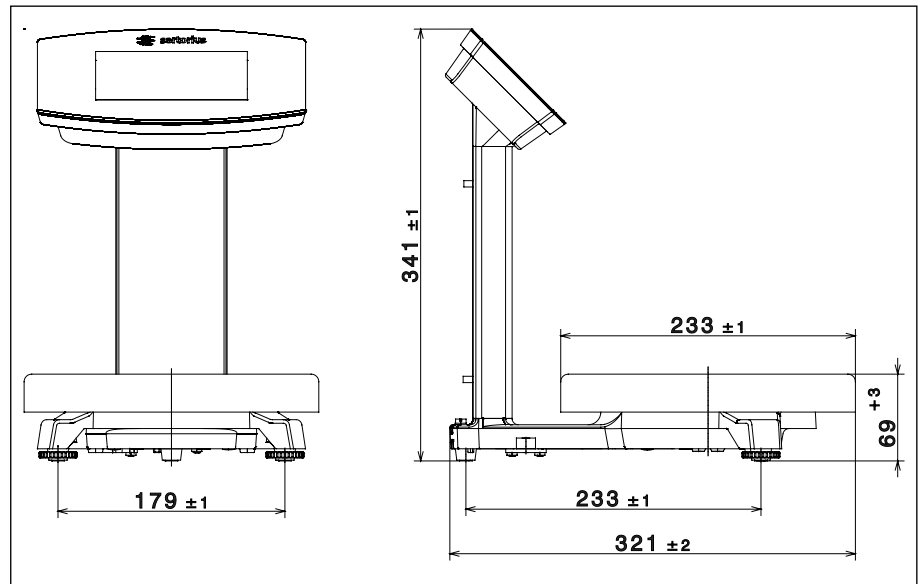

12.4.2 Model LAB1X

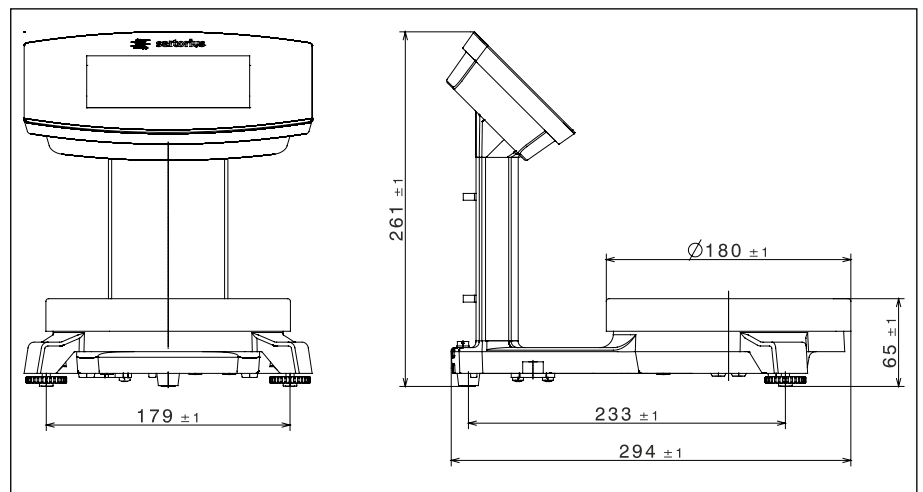

12.5 USB Port (PC Connection)

12.5.1 Purpose

This device can be connected to a PC via the USB port.

A virtual serial interface (virtual COM port, VCP) is set up on the PC as a device type via the USB port. This virtual serial interface is identified and operated by the application program.

The xBPI and SBI protocols can be transmitted via the virtual serial interface.

12.5.2 Installing the Software Driver

12.5.2.1 Installing the Software Driver (Windows Update)

- ▶ Connect the scale to the USB port of the computer (see Chapter "4.4.2 Connecting the Scale," page 20).
- ▷ Windows will detect the scale connected to the USB port as a device. If the device is being connected for the first time, the Windows Installation Wizard will run automatically.
- ▶ Follow the instructions that appear.
- ▶ To complete the installation, click on Finish.
- ▷ The virtual interface is now ready for operation.

12.5.2.2 Installing the Software Driver (via CD)

- ▶ Ensure that the scale is not connected to the PC.
- ▶ Insert the supplied CD into the PC.
- ▶ If the Installation Wizard does not start automatically after you insert the CD, then manually start driver installation via Setup.bat located on the CD.
- ▶ Follow the instructions that appear.
- ▶ To complete the installation, click on Finish.
- ▷ The virtual interface is now ready for operation.
- ▶ Connect the scale to the USB port of the computer (see Chapter "4.4.2 Connecting the Scale," page 20).



Windows® usually adds the virtual port in the position following your highest-numbered COM port.

Example:

For a PC with up to 4 COM ports, the new virtual port would then be COM5 (see Device Manager).

12.5.2.3 Installation Instructions for Windows XP® and Above

Changing the Port Number

If you use the USB interface with programs that limit the number of COM port designations (e.g., only COM1, 2, 3, 4), you may have to assign one of these port numbers to the new virtual port.

- ▶ Open the setting for the USB serial port in the Windows® Control Panel:
 - START > My Computer > Control Panel
 - System > Hardware > Device Manager
- ▶ Open the Connections submenu.
- ▶ Double-click on USB Serial Port.
- ▶ Select Port Settings > Advanced.
 - Use the "COM Port Number" button to change the port number.

Uninstalling the Driver

You can uninstall the software driver for the USB port via the Device Manager (only if the scale is connected):

- ▶ Use the right mouse button to click on the respective port.
- ▶ Then select "uninstall" from the context menu that appears.

13 Accessories

Accessories	Order Number
Power supply (5.2 V/1.4 A)	YEPS01-USB
USB connection cable	YCC01-0040M5
Mains adapter set for YEPS01-USB <ul style="list-style-type: none"> – USA and Japan (US+JP) – Europe (EU) – United Kingdom (GB) 	YEPS01-PS1
Mains adapter set for YEPS01-USB <ul style="list-style-type: none"> – Argentina (AR) – Brazil (BR) – Australia (AU) – South Africa (ZA) 	YEPS01-PS6
Mains adapter set for YEPS01-USB <ul style="list-style-type: none"> – China (CN) – India (IN) – Korea (KR) 	YEPS01-PS7
Ex-link converter	YCO14-Y
Link cable	
from converter to scale, 10 m	YCC01-0052M10
from converter to scale, 20 m	YCC01-0052M20
from converter to scale, 30 m	YCC01-0052M30
Equipotential bonding cable, 2 m	YCC01-X046M2
In-use dust cover	
for control panel, pack of 10	YDC03PMA10
for support column, PMA.Evolution, pack of 10	YDC03PMA-CO10
for weighing pan, PMA.Evolution, pack of 10	YDC03PMA-WP10
Calibration weights	
for PMA.Evolution:	
– 5 kg, accuracy class F2	YCW654-AC-00
– 2 kg, accuracy class F2	YCW624-AC-00
– 1 kg, accuracy class F2	YCW614-AC-00
for PMA.HD:	
– 2 kg, accuracy class F1	YCW623-AC-00
– 1 kg, accuracy class F1	YCW613-AC-00

14 Sartorius Service

Sartorius Service is at your disposal for queries regarding the device. For information about the service addresses, services provided or to contact a local representative, please visit the Sartorius website (www.sartorius.com).

15 Conformity & Licenses

15.1 EU Declaration of Conformity

The attached Declaration of Conformity hereby confirms compliance of the device with the directives cited.

The declaration of conformity supplied here is for conformity-assessed (verified) weighing instruments for use in the EEA.

Please keep it in a safe place.



sartorius

CE EU-Konformitätserklärung EU Declaration of Conformity

Hersteller
Manufacturer Sartorius Lab Instruments GmbH & Co. KG
37070 Goettingen, Germany

erklärt in alleiniger Verantwortung, dass das Betriebsmittel
declares under sole responsibility that the equipment

Geräteart
Device type Farbmischwaage / Ex-Link Konverter
Paint mixing scale / Ex-link converter

Baureihe
Type series EVO1Xa, EVO1Xa-cd, EVO1XaNb-cd, LAB1Xa, LAB1XaNb / YCO14-Z, YCO14-Y
a,b = 1,2,3 oder/or 4; c = C,V oder/or CV; d = 1,2,3 oder/or leer/blank

in der von uns in Verkehr gebrachten Ausführung allen einschlägigen Bestimmungen der folgenden Europäischen Richtlinien - einschließlich deren zum Zeitpunkt der Erklärung geltenden Änderungen - entspricht und die anwendbaren Anforderungen folgender harmonisierter Europäischer Normen erfüllt:
in the form as delivered fulfils all the relevant provisions of the following European Directives - including any amendments valid at the time this declaration was signed - and meets the applicable requirements of the harmonized European Standards listed below:

2014/30/EU Elektromagnetische Verträglichkeit
Electromagnetic compatibility
EN 61326-1:2013

2011/65/EU Beschränkung der Verwendung bestimmter gefährlicher Stoffe in Elektro- und Elektronikgeräten (RoHS)
Restriction of the use of certain hazardous substances in electrical and electronic equipment (RoHS)
EN 50581:2012

2014/34/EU Geräte und Schutzsysteme zur bestimmungsgemäßen Verwendung in explosionsgefährdeten Bereichen
Equipment and protective systems intended for use in potentially explosive atmospheres
EN 60079-0:2012, EN 60079-11:2012

Kennzeichnung <i>Marking</i>	II 2 G Ex ib IIB T4 Gb II (2)G [Ex ib] IIB II 3 (2)G Ex nA ic [ib Gb] IIB T4 Gc II 3 (2)G Ex nA [ib Gb] IIB T4 Gc	für/for EVO1X, LAB1X YCO14-Z YCO14-Y YCO14-Y
---------------------------------	--	--

EG-Baumusterprüfbescheinigung Nummer <i>EC-Type Examination Certificate number</i>	FM14ATEX0084X FM14ATEX0085X FM16ATEX0029X	YCO14-Z EVO1X, LAB1X YCO14-Y
---	---	------------------------------------

Anerkennung der Qualitätssicherung (Produktion) FM13ATEXQ0092
Quality Assurance Notification (production)

Jahreszahl der CE-Kennzeichenvergabe | *Year of the CE mark assignment:* 16

Sartorius Lab Instruments GmbH & Co. KG
Goettingen, 2016-09-09

Dr. Reinhard Baumfalk
Vice President R&D

Dr. Dieter Klausgrete
Head of International Certification Management

Diese Erklärung bescheinigt die Übereinstimmung mit den genannten EU-Richtlinien, ist jedoch keine Zusicherung von Eigenschaften. Bei einer mit uns nicht abgestimmten Änderung des Produktes verliert diese Erklärung ihre Gültigkeit. Die Sicherheitshinweise der zugehörigen Produktdokumentation sind zu beachten.

This declaration certifies conformity with the above mentioned EU Directives, but does not guarantee product attributes. Unauthorised product modifications make this declaration invalid. The safety information in the associated product documentation must be observed.

Doc: 2030289-02 SLI15CE002-02.de,en 1 / 1 PMF: 2030288 OP-113_fo1_2015.10.12

FCC Supplier's Declaration of Conformity



Device type Paint mixing scale + Ex-link-box

Type series EVO1X1... , LAB1X... + YC014-Y

Party issuing Supplier's Declaration of Conformity / Responsible Party – U.S. Contact Information

Sartorius Corporation
5 Orville Dr Suite 200
11716 Bohemia, NY
USA
Telephone: +1.631.254.4249

FCC Compliance Statement

This device complies with Part 15 of the FCC Rules. Operation is subject to the following two conditions: (1) This device may not cause harmful interference, and (2) this device must accept any interference received, including interference that may cause undesired operation.

Information to the user

Note: This equipment has been tested and found to comply with the limits for a **class B** digital device, pursuant to part 15 of the FCC Rules. These limits are designed to provide reasonable protection against harmful interference in a residential installation. This equipment generates, uses and can radiate radio frequency energy and if not installed and used in accordance with the instructions, may cause harmful interference to radio communications. However, there is no guarantee that interference will not occur in a particular installation. If this equipment does cause harmful interference to radio or television reception, which can be determined by turning the equipment off and on, the user is encouraged to try to correct the interference by one or more of the following measures:

- Reorient or relocate the receiving antenna.
- Increase the separation between the equipment and receiver.
- Connect the equipment into an outlet on a circuit different from that to which the receiver is connected.
- Consult the dealer or an experienced radio/TV technician for help.

Connections between the device and peripherals must be made using shielded cables in order to maintain compliance with FCC radio frequency emission limits.

Any modifications made to this device that are not approved by Sartorius may void the authority granted to the user by the FCC to operate this equipment.



UK 3066

V(0)a

EU-type examination certificate UK 3066

Issued by:

NMO

Notified Body Number 0126

In accordance with the requirements of Council Directive 2014/31/EU, this EU-type examination certificate has been issued to:

Sartorius Lab Instruments GmbH & Co KG
37070 Goettingen
Germany

In respect of a family of non-automatic weighing instruments designated the PMA and having the following characteristics:

Type	PMA-EV	PMA-HD
Class	II	III
Max	7500 g	2200 g
Min	5 g	20 g
e =	1 g	1 g
d =	0.1 g	1 g

The necessary data (principal characteristics, alterations, securing, functioning etc) for identification purposes and conditions (when applicable) are set out in the descriptive annex to this certificate.

Issue Date: 8 December 2016
Valid Until: 7 December 2026

Marek Bokota
Technical Manager
For and on behalf of the Head of Certification Body



NMO | Stanton Avenue | Teddington | TW11 0JZ | United Kingdom
 Tel +44 (0) 20 8943 7272 | Fax +44 (0) 20 8943 7270 | Web www.gov.uk/government/organisations/regulatory-delivery
 NMO is part of the Regulatory Delivery directorate within the Department for Business, Energy & Industrial Strategy

Schilder und Marken / Plates and Markings / Plaques et marques / Placas y Marcas / Etichette e Sigilli

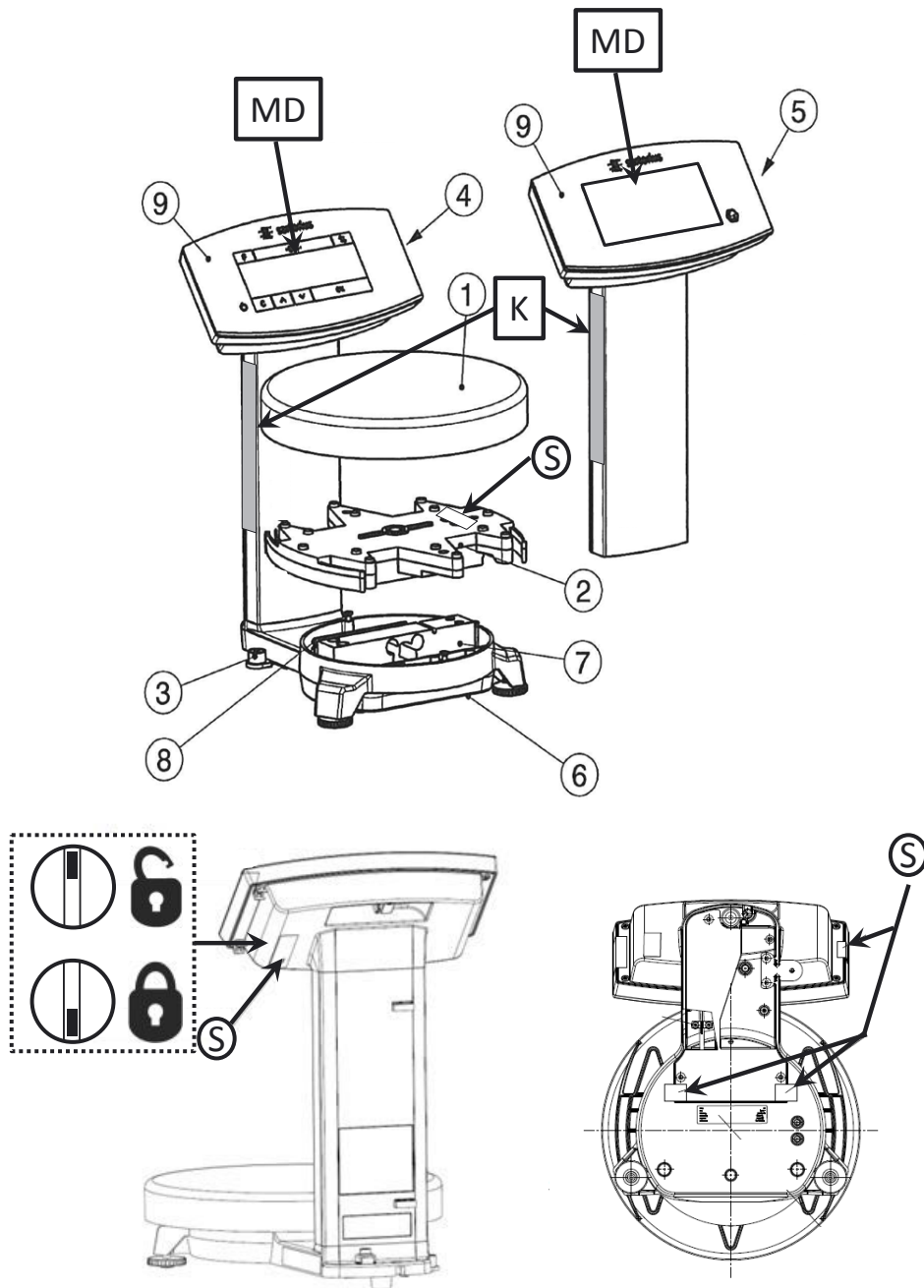

Typ Waage / Type weighing instrument / Type d'instrument de pesage / Tipo del instrumento de pesaje / Tipo di strumento per pesare: PMA-EV, PMA-HD

EG Baumusterprüfbescheinigung / EC type-examination certificate / Certificat d'examen UE de type / Certificado de examen UE de tipo / Certificato di esame UE del tipo : UK3066

- ① Schale / Pan / Plateau de pesée / Plato de pesaje / Piatto di pesata
- ② Unterschale / Subpan / Plateau inférieur / Plato inferior / Piatto inferiore
- ③ Libelle / Bubble level / Nivelles sphérique / Nivel de burbuja / Livella
- ④ Segmentiertes LCD-Display / Segmented LCD display / Afficheur à segments (LCD) / Visualizador de segmentos (LCD) / Visualizzatore a segmenti (LCD)
- ⑤ LCD Graphik-Display / LCD graphic display / Afficheur graphique (LCD) / Visualizador gráfica (LCD) / Visualizzatore grafico (LCD)
- ⑥ Grundplatte / Base plate / Plaque de montage / Placa base / Piastra di base
- ⑦ Wägesystem / Weighing system / Système de pesée / Sistema pesador / Sistema di pesatura
- ⑧ Auswertelektronik / Evaluation electronics / Dispositif de détection électronique / Electrónica de evaluación / Elettronica per la valutazione
- ⑨ Anzeigeeinrichtung / Indicating device / Dispositif indicateur / Dispositivo indicador / Dispositivo di visualizzazione

MD

Metrologische Daten Max, Min, e und wenn vorhanden d / Metrological data Max, Min, e and if existent d / Données métrologiques : Max, Min, e et, si disponible, d / Datos metrológicos: Máx, Mín, e y d, si está disponible / Dati metrologici: Max, Min, e, e d se disponibile

S

Sicherungsstempel (selbstklebende Marke oder Plombe) / Protective mark (self-adhesive mark or seal) / Marque de protection (marque ou sceau autocollant) / Sello de seguridad (marca autoadhesiva o precinto) / Sigillo di protezione (bollino autoadesivo o piombo)

K

Kennzeichnungsschild mit CE-Zeichen / Descriptive plate with CE-sign / Plaque d'identification avec marque CE de conformité / Placa de características con la marca CE / Etichetta d'identificazione con marchio CE



Programmverriegelungsschalter / Menu access switch / Commutateur d'accès au menu / Interruptor de bloqueo de programa / Commutatore di accesso al menu



gesperrt / locked / verrouillé / bloqueado / bloccato



offen / open / ouvert / abierto / aperto

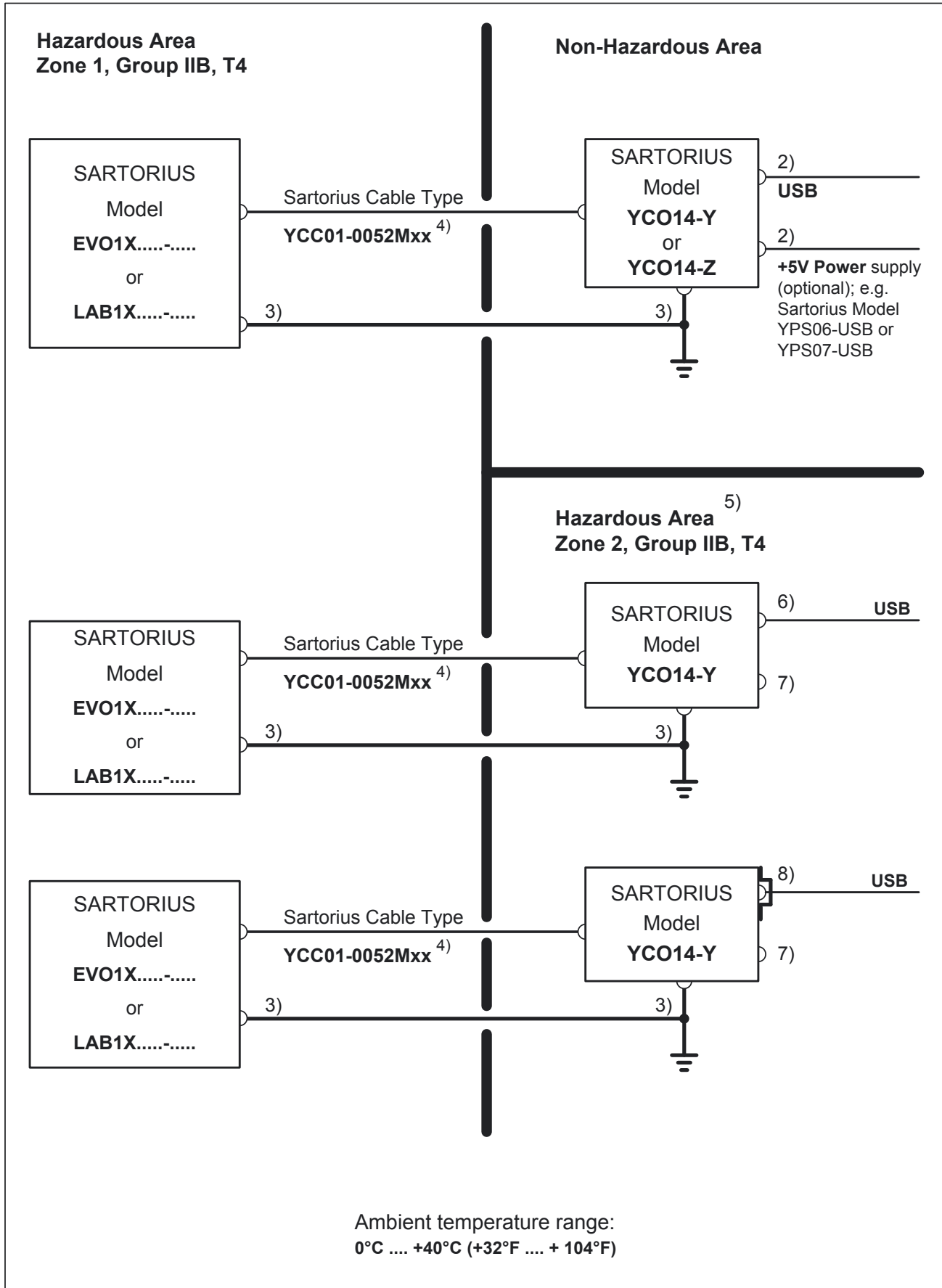

	2015-10-10	 sartorius	Safety Instructions	EVO1X.....-..... / LAB1X.....-..... + YCO14-.	
	Dr. D. Klausgrete		2023040	Revision 01	Sheet 1 of 2

These safety instructions apply to the installation, operation, maintenance and repair of the equipment

Be sure to follow the installation, operating, maintenance and servicing instructions given in the manuals supplied.

- 1) Install the equipment in compliance with applicable laws, rules and regulations, ordinances and standards. For ATEX: In particular, be sure to conform to the European Standards EN 60079-14 (Explosive atmospheres – Part 14: Electrical installations design, selection and erection). Be sure to follow the installation, operating, maintenance and servicing instructions given in the manuals supplied.
- 2) No connection to any device that uses or generates in excess of 250Vrms or 250Vdc.
- 3) All metal parts must be electrically connected to the terminal for the equipotential bonding conductor (PA). The equipment operator is obligated to connect a lead with a gauge of at least 4 mm² (cross section) to the PA terminal located on the housing of the Ex-Link converter and scale. The low resistance of this connection to the PA bus bar must be checked when the system is installed at the intended place of use. The shielding of the connecting cables may only be used for grounding when no impermissible difference in voltage is generated and, if necessary, the shielding is able to conduct the equipotential current.
- 4) Only the Sartorius cable type YCC01-0052Mxx (XX = 10 for 10m, 20 for 20m; 30 for 30m) may be used. Maximum cable length: 100ft (30.5m). The data cable connected to the scale (weighing unit) is considered as intrinsically safe circuit. Check the correct function of the data transfer before you use the equipment in a hazardous location. The equipment operator is responsible for any non-Sartorius cables used.
- 5) If the Ex-Link Converter YC014-Y is installed in Zone 2, the installation must be done in such a way that the pollution degree 2 of the YC004-Y board is guaranteed.
- 6) If the Ex-Link Converter YC014-Y is installed in Zone 2, it must be connected via an USB cable to a apparatus with intrinsically safe (Ex ic) output. The input parameters of the YC014-Y in type of protection Ex ic IIB are $U_i = 17.0V$, $I_i = 2.0A$, $P_i = \text{any}$, $C_i = 5.7\mu F$, $L_i = 0mH$ or $U_i = 16.0V$, $I_i = 2.5A$, $P_i = \text{any}$, $C_i = 5.7\mu F$, $L_i = 0mH$.
- 7) In Zone 2 the „USB Power“ port may not be used.
- 8) If the cable contains no Ex ic circuits, the cable must be protected against unintended release by use of Sartorius „Strain Relief for USB Cord“ type **YSR01**.
- 9) The equipment shall be installed in such a way that it is protected against the entry of solid foreign objects or water capable of impairing the safety of the apparatus. Reduce the risk of mechanical damage to a minimum.
- 10) Exposure to UV radiation is not allowed!
- 11) Use equipment only in the temperature ranges indicated. Avoid exposing the equipment to heat.
- 12) The connecting cable of the display unit must be prevented against damage and stress caused by strain.
- 13) If the equipment does not operate properly, unplug it immediately from line power (mains supply)!
- 14) Avoid generating static electricity. Use only a damp cloth to wipe down the equipment. The equipment operator shall be responsible for preventing any risks caused by static electricity.
- 15) Keep chemicals and other agents, which can corrode the housing seals and cable sheaths, away from the equipment. These agents include oil, grease, benzene, acetone and ozone. If you are not sure about the safety of a certain substance, please contact the manufacturer.
- 16) At reasonable intervals, have your equipment installation checked for proper functioning and safety by a trained and certified technician.
- 17) Prior to opening the equipment, disconnect the power supply or make sure that there is no potentially explosive atmosphere or any other explosion hazard in the surrounding area!
- 18) **WARNING: SUBSTITUTION OF COMPONENTS MAY IMPAIR INTRINSIC SAFETY.** If your equipment needs to be repaired, use only original spare parts supplied by the manufacturer!
- 19) Any tampering with the equipment by anyone, other than repair work done by authorized Sartorius service technicians, will result in the loss of EX conformity and in the forfeiture of all claims under the manufacturer's warranty. Only authorized specialists may open the equipment.
- 20) Modifications, including those to be carried out by Sartorius employees, may be permitted only after the express written authorization has been obtained from Sartorius.

	2015-10-10	 sartorius	Safety Instructions	EVO1X.....-..... / LAB1X.....-..... + YC014-.	
	Dr. D. Klausgrete		2023040	Revision 01	Sheet 2 of 2

1 EU-TYPE EXAMINATION CERTIFICATE



2 **Equipment or Protective systems intended for use in Potentially Explosive Atmospheres - Directive 2014/34/EU**

3 **EU-Type Examination Certificate No:** FM14ATEX0085X

4 **Equipment or protective system:** PMA.Evolution EVO1Xab-c and LAB1Xab-c.
(Type Reference and Name)

5 **Name of Applicant:** Sartorius Lab Instruments GmbH & Co. KG

6 **Address of Applicant:** Otto-Brenner-Strasse 20
Goettingen 37079
Germany

7 This equipment or protective system and any acceptable variation thereto is specified in the schedule to this certificate and documents therein referred to.

8 FM Approvals Ltd, notified body number 1725 in accordance with Article 17 of Directive 2014/34/EU of 26 February 2014, certifies that this equipment has been found to comply with the Essential Health and Safety Requirements relating to the design and construction of equipment intended for use in potentially explosive atmospheres given in Annex II to the Directive.

The examination and test results are recorded in confidential report number:

3049987 dated 27th April 2015

9 Compliance with the Essential Health and Safety Requirements, with the exception of those identified in item 15 of the schedule to this certificate, has been assessed by compliance with the following documents:

EN 60079-0:2012 + A11:2013 and EN 60079-11:2012

10 If the sign 'X' is placed after the certificate number, it indicates that the equipment is subject to specific conditions of use specified in the schedule to this certificate.

11 This EU-Type Examination certificate relates only to the design, examination and tests of the specified equipment or protective system in accordance to the directive 2014/34/EU. Further requirements of the Directive apply to the manufacturing process and supply of this equipment or protective system. These are not covered by this certificate.

12 The marking of the equipment or protective system shall include:



II 2 G Ex ib IIB T4 Gb Ta = 0°C to 40°C



cn=Mick Gower, o=FM Approvals,
ou,
email=mick.gower@fmaprovals.
com, c=GB
2017.04.27 14:07:48 +01'00'

Mick Gower
Certification Manager, FM Approvals Ltd.

Issue date: 27th April 2017

THIS CERTIFICATE MAY ONLY BE REPRODUCED IN ITS ENTIRETY AND WITHOUT CHANGE

FM Approvals Ltd, 1 Windsor Dials, Windsor, Berkshire, UK. SL4 1RS
T: +44 (0) 1753 750 000 F: +44 (0) 1753 868 700 E-mail: atex@fmaprovals.com www.fmaprovals.com

F ATEX 020 (Apr/16)

Page 1 of 3

SCHEDULE



to EU-Type Examination Certificate No. FM14ATEX0085X

13 Description of Equipment or Protective System:

The PMA.Evolution EVO1Xab-c and LAB1Xab-c are designed for the measurement of weight in the hazardous location. The PMA.Evolution contains the processing circuitry and has a touch enable LCD display with backlight facility. Power and data to the non-hazardous location are provided via the YCO14-Z Ex-Link Converter (FM14ATEX0084X) or YCO14-Y Ex-Link Converter (FM16ATEX0029X). All signal outputs to the Ex-Link Converter are in RS232 communications. The PMA.Evolution is housed within non-metallic enclosure. A dedicated potential equalization connection is provided on both the PMA.Evolution and the YCO14-. Ex-Link Converter. Power and data connections between the YCO14-. and the PMA.Evolution are made via a multi-conductor CAT6 cable.

The PMA.Evolution is available in two versions the EVO1X and the LAB1X.

PMA.Evolution EVO1Xab-c

a = Up to three letters and/or numbers or blank (not critical to safety)

b = Up to two letters and/or numbers or blank (not critical to safety)

c = Up to five letters and/or numbers or blank (not critical to safety)

PMA.Evolution LAB1Xab-c

a = Up to three letters and/or numbers or blank (not critical to safety)

b = Up to two letters and/or numbers or blank (not critical to safety)

c = Up to five letters and/or numbers or blank (not critical to safety)

14 Specific Conditions of Use:

1. The PMA.Evolution shall only be used with the YCO14-Z Ex-Link Converter (FM14ATEX0084X) or YCO14-Y Ex-Link Converter (FM16ATEX0029X).
2. The protective ground connectors on the PMA.Evolution and the YCO14-. Ex-Link Converter shall be connected together using a potential equalisation conductor with a cross-sectional area of at least 4 mm².
3. The CAT6 cable used between the PMA.Evolution and the YCO14-. Ex-Link Converter shall be obtained from Sartorius.
4. The enclosure of the PMA.Evolution is non-conducting and may generate an ignition-capable level of electrostatic charges under certain extreme conditions. The user shall ensure that the equipment is not installed in a location where it may be subjected to external conditions that might cause a build-up of electrostatic charges on non-conducting surfaces, additionally; cleaning of the equipment should be done only with a damp cloth.

15 Essential Health and Safety Requirements:

The relevant EHSRs that have not been addressed by the standards listed in this certificate have been identified and assessed in the confidential report identified in item 8.

16 Test and Assessment Procedure and Conditions:

This EU-Type Examination Certificate is the result of testing of a sample of the product submitted, in accordance with the provisions of the relevant specific standard(s), and assessment of supporting documentation. It does not imply an assessment of the whole production.

Whilst this certificate may be used in support of a manufacturer's claim for CE Marking, FM Approvals Ltd accepts no responsibility for the compliance of the equipment against all applicable Directives in all applications.

This Certificate has been issued in accordance with FM Approvals Ltd's ATEX Certification Scheme.

THIS CERTIFICATE MAY ONLY BE REPRODUCED IN ITS ENTIRETY AND WITHOUT CHANGE

FM Approvals Ltd. 1 Windsor Dials, Windsor, Berkshire, UK. SL4 1RS

T: +44 (0) 1753 750 000 F: +44 (0) 1753 868 700 E-mail: atex@fmapprovals.com www.fmapprovals.com

F ATEX 020 (Apr/16)

Page 2 of 3

SCHEDULE



to EU-Type Examination Certificate No. FM14ATEX0085X

17 Schedule Drawings

A list of the significant parts of the technical documentation is annexed to this certificate and a copy has been kept by the Notified Body.

18 Certificate History

Details of the supplements to this certificate are described below:

Date	Description
30 th April 2015	Original Issue.
26 th September 2016	<u>Supplement 1:</u> Report Reference: 3057442 dated 22 nd September 2016 Description of the Change: Add reference to Ex-Link Converter, update standards and update certificate to EU format.
27 th April 2017	<u>Supplement 2:</u> Report Reference: RR209172 dated 17 th April 2017 Description of the Change: Minor documentation update.

THIS CERTIFICATE MAY ONLY BE REPRODUCED IN ITS ENTIRETY AND WITHOUT CHANGE

FM Approvals Ltd. 1 Windsor Dials, Windsor, Berkshire, UK. SL4 1RS
 T: +44 (0) 1753 750 000 F: +44 (0) 1753 868 700 E-mail: atex@fmaprovals.com www.fmaprovals.com

F ATEX 020 (Apr/16)

Page 3 of 3

1 EU-TYPE EXAMINATION CERTIFICATE



2 **Equipment or Protective systems intended for use in Potentially Explosive Atmospheres - Directive 2014/34/EU**

3 **EU-Type Examination Certificate No: FM16ATEX0029X**

4 **Equipment or protective system: YCO14-Y
(Type Reference and Name) Ex-Link Converter**

5 **Name of Applicant: Sartorius Lab Instruments GmbH & Co KG**

6 **Address of Applicant: Otto-Brenner-Strasse 20
Goettingen
37079
Germany**

7 This equipment or protective system and any acceptable variation thereto is specified in the schedule to this certificate and documents therein referred to.

8 FM Approvals Ltd, notified body number 1725 in accordance with Article 17 of Directive 2014/34/EU of 26 February 2014, certifies that this equipment has been found to comply with the Essential Health and Safety Requirements relating to the design and construction of equipment intended for use in potentially explosive atmospheres given in Annex II to the Directive.

The examination and test results are recorded in confidential report number:

3049987 dated 27th April 2015

9 Compliance with the Essential Health and Safety Requirements, with the exception of those identified in item 15 of the schedule to this certificate, has been assessed by compliance with the following documents:

EN 60079-0:2012 + A11:2013, EN 60079-11:2012, EN 60079-15:2010, EN 60529:1991 + A2:2013

10 If the sign 'X' is placed after the certificate number, it indicates that the equipment is subject to specific conditions of use specified in the schedule to this certificate.

11 This EU-Type Examination certificate relates only to the design, examination and tests of the specified equipment or protective system in accordance to the directive 2014/34/EU. Further requirements of the Directive apply to the manufacturing process and supply of this equipment or protective system. These are not covered by this certificate.

12 The marking of the equipment or protective system shall include:



II 3 (2)G Ex nA ic [ib Gb] IIB T4 Gc Ta = 0°C to 40°C

II 3 (2)G Ex nA [ib Gb] IIB T4 Gc Ta = 0°C to 40°C



cn=Mick Gower, o=FM Approvals,
ou,
email=mick.gower@fmapprovals.
com, c=GB
2016.09.27 10:58:14 +01'00'

Mick Gower
Certification Manager, FM Approvals Ltd.

Issue date: 27th September 2016

THIS CERTIFICATE MAY ONLY BE REPRODUCED IN ITS ENTIRETY AND WITHOUT CHANGE

FM Approvals Ltd. 1 Windsor Dials, Windsor, Berkshire, UK. SL4 1RS
T: +44 (0) 1753 750 000 F: +44 (0) 1753 868 700 E-mail: atex@fmapprovals.com www.fmapprovals.com

F ATEX 020 (Apr/16)

Page 1 of 3

SCHEDULE



to EU-Type Examination Certificate No. FM16ATEX0029X

13 Description of Equipment or Protective System:

The YCO14-Y Ex-Link Converter is a dedicated device providing power and data to the PMA.Evolution EVO1X or LAB1X weighing platforms (FM14ATEX0085X). All signal outputs to the PMA.Evolution are available in RS232 communications. The YCO14-Y Ex-Link Converter is housed within non-metallic enclosure. A dedicated potential equalization connection is provided on both the PMA.Evolution and the YCO14-Y Ex-Link Converter. Power and data connections between the YCO14-Y and the PMA.Evolution are made via a multi-conductor CAT6 cable.

Ratings - The PMA.Evolution and the YCO14-Y Ex-Link Converter are designed to be used together as a system. The input voltage to the YCO14-Y Ex-Link Converter is via USB connections a $5\text{ V} \pm 0.25\text{ V}$. The ambient operating temperature is 0°C to 40°C .

YCO14-Y "ic" Input Entity Parameters:

$U_i = 17.0\text{V}$, $I_i = 2.0\text{A}$, $C_i = 5.7\mu\text{F}$, $L_i = 0\text{mH}$

$U_i = 16.0\text{V}$, $I_i = 2.5\text{A}$, $C_i = 5.7\mu\text{F}$, $L_i = 0\text{mH}$

YCO14-Y with "nA" Input Circuit (non-sparking apparatus) or outside hazardous locations:

$U_m = 250\text{V}$

14 Specific Conditions of Use:

1. The YCO14-Y Ex-Link Converter shall only be used with the PMA.Evolution.
2. The protective ground connectors on the PMA.Evolution and the YCO14-Y Ex-Link Converter shall be connected together using a potential equalisation conductor with a cross-sectional area of at least 4 mm^2 .
3. The CAT6 cable used between the PMA.Evolution and the YCO14-Y Ex-Link Converter shall be obtained from Sartorius.
4. The enclosure of the YCO14-Y is non-conducting and may generate an ignition-capable level of electrostatic charges under certain extreme conditions. The user shall ensure that the equipment is not installed in a location where it may be subjected to external conditions that might cause a build-up of electrostatic charges on non-conducting surfaces, additionally; cleaning of the equipment should be done only with a damp cloth.
5. The equipment shall be installed in such a way that it is protected against UV radiation and the entry of solid foreign objects or water capable of impairing the safety of the apparatus. Reduce the risk of mechanical damage to a minimum.
6. If the Ex-Link Converter YCO14-Y is installed in Zone 2, the installation must be done in such a way that the pollution degree 2 of the YCO14-Y board is guaranteed.
7. In Zone 2 the „USB Power“ port may not be used.
8. If the cable contains no Ex ic circuits, the cable must be protected against unintended release by use of Sartorius „Strain Relief for USB Cord“ type YSR01.

15 Essential Health and Safety Requirements:

The relevant EHSRs that have not been addressed by the standards listed in this certificate have been identified and assessed in the confidential report identified in item 8.

THIS CERTIFICATE MAY ONLY BE REPRODUCED IN ITS ENTIRETY AND WITHOUT CHANGE

FM Approvals Ltd. 1 Windsor Dials, Windsor, Berkshire, UK. SL4 1RS
T: +44 (0) 1753 750 000 F: +44 (0) 1753 868 700 E-mail: atex@fmapprovals.com www.fmapprovals.com

F ATEX 020 (Apr/16)

Page 2 of 3

SCHEDULE



to EU-Type Examination Certificate No. FM16ATEX0029X

16 Test and Assessment Procedure and Conditions:

This EU-Type Examination Certificate is the result of testing of a sample of the product submitted, in accordance with the provisions of the relevant specific standard(s), and assessment of supporting documentation. It does not imply an assessment of the whole production.

Whilst this certificate may be used in support of a manufacturer's claim for CE Marking, FM Approvals Ltd accepts no responsibility for the compliance of the equipment against all applicable Directives in all applications.

This Certificate has been issued in accordance with FM Approvals Ltd's ATEX Certification Scheme.

17 Schedule Drawings

A list of the significant parts of the technical documentation is annexed to this certificate and a copy has been kept by the Notified Body.

18 Certificate History

Details of the supplements to this certificate are described below:

Date	Description
27 th September 2016	Original Issue.

THIS CERTIFICATE MAY ONLY BE REPRODUCED IN ITS ENTIRETY AND WITHOUT CHANGE

FM Approvals Ltd. 1 Windsor Dials, Windsor, Berkshire, UK. SL4 1RS
 T: +44 (0) 1753 750 000 F: +44 (0) 1753 868 700 E-mail: atex@fmapprovals.com www.fmapprovals.com

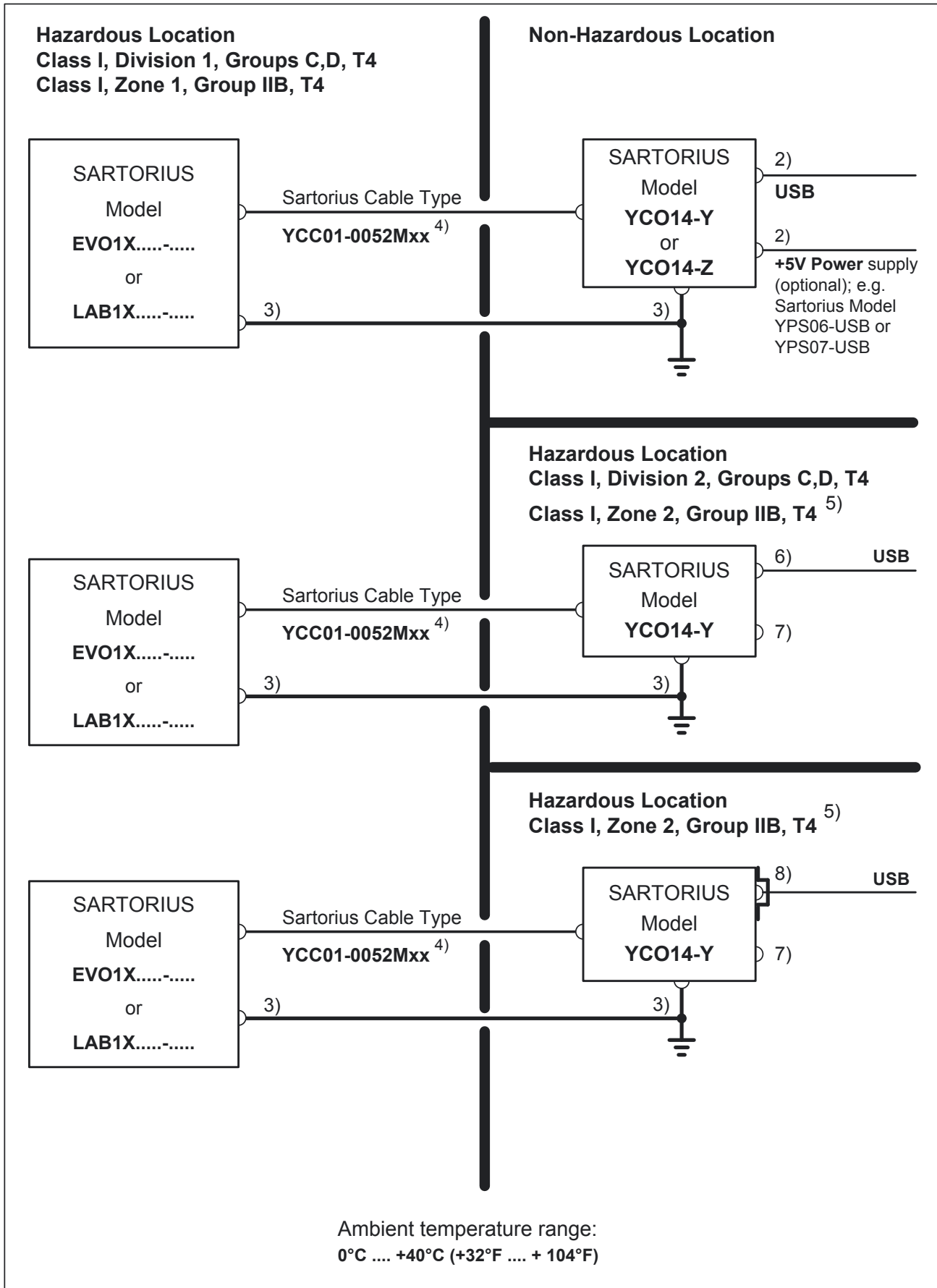

	2015-10-10	 sartorius	Control Drawing	EVO1X.....-..... / LAB1X.....-..... + YCO14-	
	Dr. D. Klausgrete		2021459	Revision 01	Sheet 1 of 2

Be sure to follow the installation, operating, maintenance and servicing instructions given in the manuals supplied.

- 1) USA: The installation must be in accordance with the National Electrical Code®, NFPA 70, Article 504 or 505 and ANSI / ISA-RP 12.6.
Canada: The installation must be in accordance with the Canadian Electrical Code®, Section 18.
- 2) No connection to any device that uses or generates in excess of 250Vrms or 250Vdc.
- 3) USA: The apparatus must be connected to a suitable ground electrode per National Electrical Code®, NFPA 70, Article 504 or 505. The resistance of the ground pad must be less than 1 ohm.
Canada: The apparatus must be connected to a suitable ground electrode per Canadian Electrical Code®, Section 18. The resistance of the ground pad must be less than 1 ohm.
- 4) Only the Sartorius cable type YCC01-0052Mxx (XX = 10 for 10m, 20 for 20m; 30 for 30m) may be used. Maximum cable length: 100ft (30.5m). The equipment operator is responsible for any non-Sartorius cables used.
- 5) If the Ex-Link Converter YCO14-Y is installed in Zone 2, the installation must be done in such a way that the pollution degree 2 of the YCO04-Y board is guaranteed.
- 6) For use in Division 2: The Ex-Link Converter YCO14-Y must be connected via an USB cable to a nonincendive apparatus with nonincendive field wiring output. The input parameters of the YCO14-Y are
Vmax = 17.0V, Imax = 2.0A, Pmax = any, Ci = 5.7µF, Li = 0mH or Vmax = 16.0V, Imax = 2.5A, Pmax = any, Ci = 5.7µF, Li = 0mH (Entity parameters).
For use in Zone 2:
The Ex-Link Converter YCO14-Y must be connected via an USB cable to a apparatus with intrinsically safe (Ex ic) output. The input parameters of the YCO14-Y in type of protection Ex ic IIB are
Ui = 17.0V, li = 2.0A, Pi = any, Ci = 5.7µF, Li = 0mH or Ui = 16.0V, li = 2.5A, Pi = any, Ci = 5.7µF, Li = 0mH (Entity parameters).
- 7) In Zone 2 the „USB Power“ port may not be used.
- 8) If the cable contains no Ex ic circuits, the cable must be protected against unintended release by use of Sartorius „Strain Relief for USB Cord“ type **YSR01**.
- 9) The equipment shall be installed in such a way that it is protected against the entry of solid foreign objects or water capable of impairing the safety of the apparatus. Reduce the risk of mechanical damage to a minimum.
- 10) Exposure to UV radiation is not allowed!
- 11) Use equipment only in the temperature ranges indicated. Avoid exposing the equipment to heat.
- 12) The connecting cable of the display unit must be prevented against damage and stress caused by strain.
- 13) If the equipment does not operate properly, unplug it immediately from line power (mains supply)!
- 14) Avoid generating static electricity. Use only a damp cloth to wipe down the equipment. The equipment operator shall be responsible for preventing any risks caused by static electricity.
- 15) Keep chemicals and other agents, which can corrode the housing seals and cable sheaths, away from the equipment. These agents include oil, grease, benzene, acetone and ozone. If you are not sure about the safety of a certain substance, please contact the manufacturer.
- 16) At reasonable intervals, have your equipment installation checked for proper functioning and safety by a trained and certified technician.
- 17) Prior to opening the equipment, disconnect the power supply or make sure that there is no potentially explosive atmosphere or any other explosion hazard in the surrounding area!
- 18) **WARNING: SUBSTITUTION OF COMPONENTS MAY IMPAIR INTRINSIC SAFETY.**
If your equipment needs to be repaired, use only original spare parts supplied by the manufacturer!
- 19) Any tampering with the equipment by anyone, other than repair work done by authorized Sartorius service technicians, will result in the loss of EX conformity and in the forfeiture of all claims under the manufacturer's warranty. Only authorized specialists may open the equipment.
- 20) Modifications, including those to be carried out by Sartorius employees, may be permitted only after the express written authorization has been obtained from Sartorius.

	2015-10-10		Control Drawing		EVO1X..... / LAB1X..... + YCO14-
	Dr. D. Klausgrete		2021459	Revision 01	Sheet 2 of 2



CERTIFICATE OF CONFORMITY

1. **HAZARDOUS (CLASSIFIED) LOCATION ELECTRICAL EQUIPMENT PER US REQUIREMENTS**
2. **Certificate No:** FM16US0226X
3. **Equipment:** PMA.Evolution EVO1X.....-..... and LAB1X.....-.....
(Type Reference and Name) Weighing Unit
 Type YCO14-Y and YCO14-Z
 Ex-Link Converter
4. **Name of Listing Company:** Sartorius Lab Instruments GmbH & Co. KG
5. **Address of Listing Company:** Otto-Brenner-Strasse 20
 Goettingen
 37079
 Germany
6. The examination and test results are recorded in confidential report number:
 3049987 dated 27th April 2016
7. FM Approvals LLC, certifies that the equipment described has been found to comply with the following Approval standards and other documents:
 FM Class 3600:2011, FM Class 3610: 2015, FM Class 3611:2004, FM Class 3810:2005,
 ANSI/ISA 60079-0:2009, ANSI/ISA 60079-11:2011, ANSI/ISA 60079-15:2009 ANSI/IEC 60529:2004
8. If the sign 'X' is placed after the certificate number, it indicates that the equipment is subject to specific conditions of use specified in the schedule to this certificate.
9. This certificate relates to the design, examination and testing of the products specified herein. The FM Approvals surveillance audit program has further determined that the manufacturing processes and quality control procedures in place are satisfactory to manufacture the product as examined, tested and Approved.
10. **Equipment Ratings:**
YCO14-Y Ex-Link Converter
 Associated Intrinsically Safe apparatus for connection to Class I, Division 1, Groups C and D; Associated Intrinsically Safe for connection to Class I, Zone 1, Group IIB; Non-incendive for use in Class I, Division 2, Group C and D with Intrinsically Safe outputs for connection to Class I, Division 1, Groups C and D; Non-

Certificate issued by:

J.E. Marquedant

 J.E. Marquedant
 Manager, Electrical Systems

22 September 2016

 Date

To verify the availability of the Approved product, please refer to www.approvalguide.com

THIS CERTIFICATE MAY ONLY BE REPRODUCED IN ITS ENTIRETY AND WITHOUT CHANGE

FM Approvals LLC. 1151 Boston-Providence Turnpike, Norwood, MA 02062 USA
 T: +1 (1) 781 762 4300 F: +1 (1) 781 762 9375 E-mail: information@fmaprovals.com www.fmaprovals.com

SCHEDULE



US Certificate Of Conformity No: FM16US0226X

Sparking and Intrinsically Safe apparatus for Class 1, Zone 2, AEx nA ic [ib] IIB with connection to Class 1, Zone 1, Group IIB; Non-sparking apparatus for Class 1, Zone 2, AEx nA [ib] IIB for connection to Class 1, Zone 1, Group IIB hazardous (classified) locations in accordance with drawing 2021459. Ambient temperature range 0°C to 40°C. Indoor locations only.

YCO14-Z Ex-Link Converter

Associated intrinsically safe apparatus for connection to Class I, Division 1, Groups C and D hazardous (classified) locations in accordance with drawing 2021459, Associated Intrinsically Safe for connection to Class I, Zone 1, Group IIB hazardous (classified) locations in accordance with drawing 2021459. Ambient temperature range 0°C to 40°C. Indoor locations only.

PMA.Evolution EVO1Xab-c

PMA.Evolution LAB1Xab-c

Intrinsically Safe for Class I, Division 1, Groups C and D, hazardous (classified) locations in accordance with drawing 2021459, Intrinsically Safe for Class I, Zone 1, Group IIB hazardous (classified) locations in accordance with drawing 2021459. Temperature class T4 at an ambient temperature of 0°C to 40°C. Indoor locations only.

11. The marking of the equipment shall include:

YCO14-Y Ex-Link Converter

AIS Class I, Division 1, Groups C and D; [AEx/Ex ia] for Class I, Zone 1, Group IIB;
 NI-AIS Class I, Division 2, Group C and D T4;
 Class I, Zone 2, AEx nA ic [ib] IIB T4
 Class I, Zone 2, AEx nA [ib] IIB T4
 in accordance with drawing 2021459
 Ambient temperature range 0°C to 40°C

YCO14-Z Ex-Link Converter

AIS Class I, Division 1, Groups C and D; AIS Class I, Zone 1, Group IIB
 in accordance with drawing 2021459
 Ambient temperature range 0°C to 40°C

PMA.Evolution EVO1Xab-c

PMA.Evolution LAB1Xab-c

IS Class I, Division 1, Groups C and D T4; Class I, Zone 1, Group IIB T4
 in accordance with drawing 2021459
 Ambient temperature range 0°C to 40°C.

12. **Description of Equipment:**

The PMA.Evolution is designed for the measurement of weight in the hazardous location. The PMA.Evolution contains the processing circuitry and has a touch enable LCD display with backlight facility. Power and data to the non-hazardous or unclassified location are provided via the YCO14-Z or YCO14-Y Ex-Link Converter. All signal outputs to the YCO14-Z or YCO14-Y Ex-Link Converter are available in RS232 communications. Both the PMA.Evolution and the YCO14-Z or YCO14-Y Ex-Link Converter are housed within non-metallic enclosures. A dedicated potential equalization connection is provided on both the PMA.Evolution and the YCO14-Z or YCO14-Y Ex-Link Converter. Power and data connections between the YCO14-Z and YCO14-Y Ex-Link Converter and the PMA.Evolution are made via a multi-conductor CAT6 cable.

THIS CERTIFICATE MAY ONLY BE REPRODUCED IN ITS ENTIRETY AND WITHOUT CHANGE

FM Approvals LLC, 1151 Boston-Providence Turnpike, Norwood, MA 02062 USA

T: +1 (1) 781 762 4300 F: +1 (1) 781 762 9375 E-mail: information@fmapprovals.com www.fmapprovals.com

SCHEDULE



US Certificate Of Conformity No: FM16US0226X

Ratings - The PMA.Evolution and the YCO14-. Ex-Link Converter are designed to be used together as a system. The input voltage to the YCO14-. Ex-Link Converter is via USB connections a $5\text{ V} \pm 0.25\text{ V}$. The ambient operating temperature range of the PMA.Evolution and YCO14-. is 0°C to 40°C .

YCO14-Y Non-incendive Field Wiring Parameters:
 $V_{\text{max}} = 17.0\text{V}$, $I_{\text{max}} = 2.0\text{A}$, $C_i = 5.7\mu\text{F}$, $L_i = 0\text{mH}$
 $V_{\text{max}} = 16.0\text{V}$, $I_i = 2.5\text{A}$, $C_i = 5.7\mu\text{F}$, $L_i = 0\text{mH}$

YCO14-Y "ic" Input Entity Parameters:
 $U_i = 17.0\text{V}$, $I_i = 2.0\text{A}$, $C_i = 5.7\mu\text{F}$, $L_i = 0\text{mH}$
 $U_i = 16.0\text{V}$, $I_i = 2.5\text{A}$, $C_i = 5.7\mu\text{F}$, $L_i = 0\text{mH}$

YCO14-Y with "nA" Input Circuit (non-sparking apparatus) or outside hazardous locations:
 $U_m = 250\text{V}$

YCO14-Y Ex-Link Converter

YCO14-Z Ex-Link Converter

PMA.Evolution EVO1Xab-c

- a = Up to three letters and/or numbers or blank (not critical to safety)
- b = Up to two letters and/or numbers or blank (not critical to safety)
- c = Up to five letters and/or numbers or blank (not critical to safety)

PMA.Evolution LAB1Xab-c

- a = Up to three letters and/or numbers or blank (not critical to safety)
- b = Up to two letters and/or numbers or blank (not critical to safety)
- c = Up to five letters and/or numbers or blank (not critical to safety)

13. **Specific Conditions of Use:**

YCO14-Y:

1. The YCO14-Y Ex-Link Converter shall only be used with the PMA.Evolution.
2. The protective ground connectors on the PMA.Evolution and the YCO14-Y Ex-Link Converter shall be connected together using a potential equalisation conductor with a cross-sectional area of at least 4 mm^2 .
3. The CAT6 cable used between the PMA.Evolution and the YCO14-Y Ex-Link Converter shall be obtained from Sartorius.
4. The enclosure of the YCO14-Y is non-conducting and may generate an ignition-capable level of electrostatic charges under certain extreme conditions. The user shall ensure that the equipment is not installed in a location where it may be subjected to external conditions that might cause a build-up of electrostatic charges on non-conducting surfaces, additionally; cleaning of the equipment should be done only with a damp cloth.
5. The equipment shall be installed in such a way that it is protected against UV radiation and the entry of solid foreign objects or water capable of impairing the safety of the apparatus. Reduce the risk of mechanical damage to a minimum.
6. If the Ex-Link Converter YCO14-Y is installed in Zone 2, the installation must be done in such a way that the pollution degree 2 of the YCO14-Y board is guaranteed.
7. In Zone 2 the „USB Power“ port may not be used.

THIS CERTIFICATE MAY ONLY BE REPRODUCED IN ITS ENTIRETY AND WITHOUT CHANGE

FM Approvals LLC. 1151 Boston-Providence Turnpike, Norwood, MA 02062 USA
 T: +1 (1) 781 762 4300 F: +1 (1) 781 762 9375 E-mail: information@fmapprovals.com www.fmapprovals.com

F 347 (Mar 16)

Page 3 of 4

SCHEDULE



US Certificate Of Conformity No: FM16US0226X

YCO14-Z:

1. The YCO-14Z Ex-Link Converter shall only be used with the PMA.Evolution.
2. The protective ground connectors on the PMA.Evolution and the YCO14-Z Ex-Link Converter shall be connected together using a potential equalisation conductor with a cross-sectional area of at least 4 mm².
3. The CAT6 cable used between the PMA.Evolution and the YCO14-Z Ex-Link Converter shall be obtained from Sartorius.

PMA.Evolution:

1. The PMA.Evolution shall only be used with the YCO14-Y or YCO14-Z Ex-Link Converter
2. The protective ground connectors on the PMA.Evolution and the YCO14-Y or YCO14-Z Converter shall be connected together using a potential equalisation conductor with a cross-sectional area of at least 4mm².
3. The CAT6 cable used between the PMA.Evolution and the YCO14-Y or YCO14-Z Converter shall be obtained from Sartorius.
4. The enclosure of the PMA.Evolution is non-conducting and may generate an ignition-capable level of electrostatic charges under certain extreme conditions. The user shall ensure that the equipment is not installed in a location where it may be subjected to external conditions that might cause a build-up of electrostatic charges on non-conducting surfaces, additionally; cleaning of the equipment should be done only with a damp cloth.

Test and Assessment Procedure and Conditions:

This Certificate has been issued in accordance with FM Approvals US Certification Requirements.

Schedule Drawings

A copy of the technical documentation has been kept by FM Approvals.

Certificate History

Details of the supplements to this certificate are described below:

Date	Description
27 th April 2015	Original Issue.
22 nd September 2016	<u>Supplement 1:</u> Report Reference: – 3057442 dated 22 nd September 2016 Description of the Change: Add YCO14-Y Ex-Line Converter

THIS CERTIFICATE MAY ONLY BE REPRODUCED IN ITS ENTIRETY AND WITHOUT CHANGE

FM Approvals LLC, 1151 Boston-Providence Turnpike, Norwood, MA 02062 USA
T: +1 (1) 781 762 4300 F: +1 (1) 781 762 9375 E-mail: information@fmaprovals.com www.fmaprovals.com



CERTIFICATE OF CONFORMITY

1. **HAZARDOUS LOCATION ELECTRICAL EQUIPMENT PER CANADIAN REQUIREMENTS**
2. **Certificate No:** FM16CA0124X
3. **Equipment:** PMA.Evolution EVO1X.....-..... and LAB1X.....-.....
(Type Reference and Name) Weighing Unit
 Type YCO14-Y and YCO14-Z
 Ex-Link Converter
4. **Name of Listing Company:** Sartorius Lab Instruments GmbH & Co KG
5. **Address of Listing Company:** Otto-Brenner-Strasse 20
 Goettingen
 37079
 Germany
6. The examination and test results are recorded in confidential report number:
 3049987 dated 27th April 2016
7. FM Approvals LLC, certifies that the equipment described has been found to comply with the following Approval standards and other documents:
 CSA-C22.2 No. 142-M1987:R2014, CSA-C22.2 No. 157-92:R2012, CSA-C22.2 No. 1010.1:R2004,
 CAN/CSA-C22.2 No. 60079-0:2011, CAN/CSA-C22.2 No. 60079-11:2011,
 CAN/CSA-C22.2 No. 60079-15:2011
8. If the sign 'X' is placed after the certificate number, it indicates that the equipment is subject to specific conditions of use specified in the schedule to this certificate.
9. This certificate relates to the design, examination and testing of the products specified herein. The FM Approvals surveillance audit program has further determined that the manufacturing processes and quality control procedures in place are satisfactory to manufacture the product as examined, tested and Approved.
10. **Equipment Ratings:**
YCO14-Y Ex-Link Converter
 Associated Intrinsically Safe apparatus for connection to Class I, Division 1, Groups C and D; Associated Intrinsically Safe for connection to Class I, Zone 1, Group IIB; Non-incendive for use in Class I, Division 2,

Certificate issued by:

J.E. Marquedant

 J.E. Marquedant
 Manager, Electrical Systems

22 September 2016

 Date

To verify the availability of the Approved product, please refer to www.approvalguide.com

THIS CERTIFICATE MAY ONLY BE REPRODUCED IN ITS ENTIRETY AND WITHOUT CHANGE

FM Approvals LLC. 1151 Boston-Providence Turnpike, Norwood, MA 02062 USA
 T: +1 (1) 781 762 4300 F: +1 (1) 781 762 9375 E-mail: information@fmaprovals.com www.fmaprovals.com

SCHEDULE



Canadian Certificate Of Conformity No: FM16CA0124X

Group C and D with Intrinsically Safe outputs for connection to Class I, Division 1, Groups C and D; Non-Sparking and Intrinsically Safe apparatus for Class 1, Zone 2, AEx nA ic [ib] IIB with connection to Class 1, Zone 1, Group IIB; Non-sparking apparatus for Class 1, Zone 2, AEx nA [ib] IIB for connection to Class 1, Zone 1, Group IIB hazardous (classified) locations in accordance with drawing 2021459. Ambient temperature range 0°C to 40°C. Indoor locations only.

YCO14-Z Ex-Link Converter

Associated intrinsically safe apparatus for connection to Class I, Division 1, Groups C and D hazardous (classified) locations in accordance with drawing 2021459, Associated Intrinsically Safe for connection to Class I, Zone 1, Group IIB hazardous (classified) locations in accordance with drawing 2021459. Ambient temperature range 0°C to 40°C. Indoor locations only

PMA.Evolution EVO1Xab-c

PMA.Evolution LAB1Xab-c

Intrinsically Safe for Class I, Division 1, Groups C and D, hazardous (classified) locations in accordance with drawing 2021459, Intrinsically Safe for Class I, Zone 1, Group IIB hazardous (classified) locations in accordance with drawing 2021459. Temperature class T4 at an ambient temperature of 0°C to 40°C. Indoor locations only.

11. The marking of the equipment shall include:

YCO14-Y Ex-Link Converter

AIS Class I, Division 1, Groups C and D; [AEx/Ex ia] for Class I, Zone 1, Group IIB;
NI-AIS Class I, Division 2, Group C and D T4;
Class 1, Zone 2, Ex nA ic [ib] IIB T4
Class 1, Zone 2, Ex nA [ib] IIB T4
in accordance with drawing 2021459
Ambient temperature range 0°C to 40°C

YCO14-Z Ex-Link Converter

AIS Class I, Division 1, Groups C and D; Class I, Zone 1, Group IIB
in accordance with drawing 2021459
Ambient temperature range 0°C to 40°C

PMA.Evolution EVO1Xab-c

PMA.Evolution LAB1Xab-c

IS Class I, Division 1, Groups C and D T4; Class I, Zone 1, Group IIB T4
in accordance with drawing 2021459
Ambient temperature range 0°C to 40°C.

12. **Description of Equipment:**

The PMA.Evolution is designed for the measurement of weight in the hazardous location. The PMA.Evolution contains the processing circuitry and has a touch enable LCD display with backlight facility. Power and data to the non-hazardous or unclassified location are provided via the YCO14-Z or YCO14-Y Ex-Link Converter. All signal outputs to the YCO14-Z or YCO14-Y Ex-Link Converter are available in RS232 communications. Both the PMA.Evolution and the YCO14-Z or YCO14-Y Ex-Link Converter are housed within non-metallic enclosures. A dedicated potential equalization connection is provided on both the PMA.Evolution and the YCO14-Z or YCO14-Y Ex-Link Converter. Power and data connections between the YCO14-Z and YCO14-Y Ex-Link Converter and the PMA.Evolution are made via a multi-conductor CAT6 cable.

THIS CERTIFICATE MAY ONLY BE REPRODUCED IN ITS ENTIRETY AND WITHOUT CHANGE

FM Approvals LLC, 1151 Boston-Providence Turnpike, Norwood, MA 02062 USA

T: +1 (1) 781 762 4300 F: +1 (1) 781 762 9375 E-mail: information@fmapprovals.com www.fmapprovals.com

SCHEDULE



Canadian Certificate Of Conformity No: FM16CA0124X

Ratings - The PMA.Evolution and the YCO14 Ex-Link Converter are designed to be used together as a system. The input voltage to the YCO14-Z Ex-Link Converter is via USB connections a $5\text{ V} \pm 0.25\text{ V}$. The ambient operating temperature range of the PMA.Evolution and YCO14 is 0°C to 40°C .

YCO14-Y Non-incendive Field Wiring Parameters:
 $V_{\text{max}} = 17.0\text{V}$, $I_{\text{max}} = 2.0\text{A}$, $C_i = 5.7\mu\text{F}$, $L_i = 0\text{mH}$
 $V_{\text{max}} = 16.0\text{V}$, $I_i = 2.5\text{A}$, $C_i = 5.7\mu\text{F}$, $L_i = 0\text{mH}$

YCO14-Y "ic" Input Entity Parameters:
 $U_i = 17.0\text{V}$, $I_i = 2.0\text{A}$, $C_i = 5.7\mu\text{F}$, $L_i = 0\text{mH}$
 $U_i = 16.0\text{V}$, $I_i = 2.5\text{A}$, $C_i = 5.7\mu\text{F}$, $L_i = 0\text{mH}$

YCO14-Y Ex-Link Converter

YCO14-Z Ex-Link Converter

PMA.Evolution EVO1Xab-c

- a = Up to three letters and/or numbers or blank (not critical to safety)
- b = Up to two letters and/or numbers or blank (not critical to safety)
- c = Up to five letters and/or numbers or blank (not critical to safety)

PMA.Evolution LAB1Xab-c

- a = Up to three letters and/or numbers or blank (not critical to safety)
- b = Up to two letters and/or numbers or blank (not critical to safety)
- c = Up to five letters and/or numbers or blank (not critical to safety)

13. **Specific Conditions of Use:**

YCO14-Y:

1. The YCO14-Y Ex-Link Converter shall only be used with the PMA.Evolution.
2. The protective ground connectors on the PMA.Evolution and the YCO14-Y Ex-Link Converter shall be connected together using a potential equalisation conductor with a cross-sectional area of at least 4 mm^2 .
3. The CAT6 cable used between the PMA.Evolution and the YCO14-Y Ex-Link Converter shall be obtained from Sartorius.
4. The enclosure of the YCO14-Y is non-conducting and may generate an ignition-capable level of electrostatic charges under certain extreme conditions. The user shall ensure that the equipment is not installed in a location where it may be subjected to external conditions that might cause a build-up of electrostatic charges on non-conducting surfaces, additionally; cleaning of the equipment should be done only with a damp cloth.
5. The equipment shall be installed in such a way that it is protected against UV radiation and the entry of solid foreign objects or water capable of impairing the safety of the apparatus. Reduce the risk of mechanical damage to a minimum.
6. If the Ex-Link Converter YCO14-Y is installed in Zone 2, the installation must be done in such a way that the pollution degree 2 of the YCO14-Y board is guaranteed.
7. In Zone 2 the „USB Power“ port may not be used.

YCO14-Z:

1. The YCO-14Z Ex-Link Converter shall only be used with the PMA.Evolution.
2. The protective ground connectors on the PMA.Evolution and the YCO14-Z Ex-Link Converter shall be

THIS CERTIFICATE MAY ONLY BE REPRODUCED IN ITS ENTIRETY AND WITHOUT CHANGE

FM Approvals LLC. 1151 Boston-Providence Turnpike, Norwood, MA 02062 USA
 T: +1 (1) 781 762 4300 F: +1 (1) 781 762 9375 E-mail: information@fmaprovals.com www.fmaprovals.com

SCHEDULE



Canadian Certificate Of Conformity No: FM16CA0124X

connected together using a potential equalisation conductor with a cross-sectional area of at least 4 mm².
3. The CAT6 cable used between the PMA.Evolution and the YCO14-Z Ex-Link Converter shall be obtained from Sartorius.

PMA.Evolution:

1. The PMA.Evolution shall only be used with the YCO14-Y or YCO14-Z Ex-Link Converter
2. The protective ground connectors on the PMA.Evolution and the YCO14-Y or YCO14-Z Converter shall be connected together using a potential equalisation conductor with a cross-sectional area of at least 4 mm².
3. The CAT6 cable used between the PMA.Evolution and the YCO14-Y or YCO14-Z Converter shall be obtained from Sartorius.
4. The enclosure of the PMA.Evolution is non-conducting and may generate an ignition-capable level of electrostatic charges under certain extreme conditions. The user shall ensure that the equipment is not installed in a location where it may be subjected to external conditions that might cause a build-up of electrostatic charges on non-conducting surfaces, additionally; cleaning of the equipment should be done only with a damp cloth.

14. Test and Assessment Procedure and Conditions:

This Certificate has been issued in accordance with FM Approvals Canadian Certification Scheme.

15. Schedule Drawings

A copy of the technical documentation has been kept by FM Approvals.

16. Certificate History

Details of the supplements to this certificate are described below:

Date	Description
27 th April 2015	Original Issue.
22 nd September 2016	<u>Supplement 1:</u> Report Reference: – 3057442 dated 22 nd September 2016. Description of the Change: Add YCO14-Y Ex-Line Converter

THIS CERTIFICATE MAY ONLY BE REPRODUCED IN ITS ENTIRETY AND WITHOUT CHANGE

FM Approvals LLC. 1151 Boston-Providence Turnpike, Norwood, MA 02062 USA
T: +1 (1) 781 762 4300 F: +1 (1) 781 762 9375 E-mail: information@fmaprovals.com www.fmaprovals.com



IECEx Certificate of Conformity

INTERNATIONAL ELECTROTECHNICAL COMMISSION IEC Certification Scheme for Explosive Atmospheres

for rules and details of the IECEx Scheme visit www.iecex.com

Certificate No.:	IECEx FME 14.0008X	Issue No: 1	Certificate history:
Status:	Current	Page 1 of 4	Issue No. 1 (2016-09-27) Issue No. 0 (2015-04-30)
Date of Issue:	2016-09-27		
Applicant:	Sartorius Lab Instruments GmbH & Co. KG Otto-Brenner-Strasse 20 Goettingen Germany		
Equipment:	PMA.Evolution Paint Mixing Scale EVO1Xab-c and LAB1Xab-c, YCO14-Y and YCO14-Z Ex-Link Converter		
Optional accessory:			
Type of Protection:	Intrinsic Safety, Non-Sparking		
Marking:	Ex ib IIB T4 Gb 0°C ≤ Ta ≤ 40°C – PMA. Evolution [Ex ib Gb] IIB 0°C ≤ Ta ≤ 40°C – YCO14-Z Ex-Link Converter Ex nA ic [ib Gb] IIB T4 Gc 0°C ≤ Ta ≤ 40°C – YCO14-Y Ex-Link Converter Ex nA [ib Gb] IIB T4 Gc 0°C ≤ Ta ≤ 40°C – YCO14-Y Ex-Link Converter		

Approved for issue on behalf of the IECEx
Certification Body:

Mick Gower

Position:

Certification Manager

Signature:
(for printed version)

Date:

1. This certificate and schedule may only be reproduced in full.
2. This certificate is not transferable and remains the property of the issuing body.
3. The Status and authenticity of this certificate may be verified by visiting the [Official IECEx Website](http://www.iecex.com).

Certificate issued by:

FM Approvals Ltd
1 Windsor Dials
SL4 1RS Windsor
United Kingdom



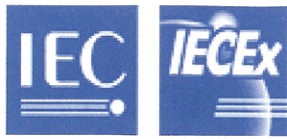

IECEx Certificate of Conformity

Certificate No: IECEx FME 14.0008X Issue No: 1
 Date of Issue: 2016-09-27 Page 2 of 4
 Manufacturer: Sartorius Lab Instruments GmbH & Co. KG
 Goettingen
 Germany

Additional Manufacturing location(s):

This certificate is issued as verification that a sample(s), representative of production, was assessed and tested and found to comply with the IEC Standard list below and that the manufacturer's quality system, relating to the Ex products covered by this certificate, was assessed and found to comply with the IECEx Quality system requirements. This certificate is granted subject to the conditions as set out in IECEx Scheme Rules, IECEx 02 and Operational Documents as amended.

STANDARDS:

The electrical apparatus and any acceptable variations to it specified in the schedule of this certificate and the identified documents, was found to comply with the following standards:

IEC 60079-0 : 2011 Explosive atmospheres - Part 0: General requirements
 Edition:6.0
 IEC 60079-11 : 2011 Explosive atmospheres - Part 11: Equipment protection by intrinsic safety "i"
 Edition:6.0
 IEC 60079-15 : 2010 Explosive atmospheres - Part 15: Equipment protection by type of protection "n"
 Edition:4

This Certificate does not indicate compliance with electrical safety and performance requirements other than those expressly included in the Standards listed above.

TEST & ASSESSMENT REPORTS:

A sample(s) of the equipment listed has successfully met the examination and test requirements as recorded in

Test Report:

[GB/FME/ExTR14.0009/01](#) [GB/FME/ExTR14.0009/00](#)

Quality Assessment Report:

[GB/FME/QAR13.0020/00](#)



IECEx Certificate of Conformity

Certificate No: IECEx FME 14.0008X

Issue No: 1

Date of Issue: 2016-09-27

Page 3 of 4

Schedule

EQUIPMENT:

Equipment and systems covered by this certificate are as follows:

The PMA.Evolution is designed for the measurement of weight in the hazardous location. The PMA.Evolution contains the processing circuitry and has a touch enable LCD display with backlight facility. Power and data to the non-hazardous location are provided via the YCO14-Y or YCO14-Z Ex-Link Converter. All signal outputs to the PMA.Evolution are available in RS232 communications. Both the PMA.Evolution and the Ex-Link Converters are housed within non-metallic enclosures. A dedicated potential equalization connection is provided on both the PMA.Evolution and the Ex-Link Converter. Power and data connections between the Ex-Link Converter and the PMA. Evolution are made via a multi-conductor CAT6 cable.

The PMA.Evolution is available in two versions the EVO1X and the LAB1X.

CONDITIONS OF CERTIFICATION: YES as shown below:

1. The PMA.Evolution shall only be used with the YCO14-Y or YCO14-Z Ex-Link Converter.
2. The protective ground connectors on the PMA.Evolution and the YCO14-Y or YCO14-Z Ex-Link Converter shall be connected together using a potential equalisation conductor with a cross-sectional area of at least 4 mm².
3. The CAT6 cable used between the PMA.Evolution and the YCO14-Y or YCO14-Z Ex-Link Converter shall be obtained from Sartorius.
4. The enclosure of the PMA.Evolution is non-conducting and may generate an ignition-capable level of electrostatic charges under certain extreme conditions. The user shall ensure that the equipment is not installed in a location where it may be subjected to external conditions that might cause a build-up of electrostatic charges on non-conducting surfaces, additionally; cleaning of the equipment should be done only with a damp cloth.
5. The enclosure of the YCO14-Y is non-conducting and may generate an ignition-capable level of electrostatic charges under certain extreme conditions. The user shall ensure that the equipment is not installed in a location where it may be subjected to external conditions that might cause a build-up of electrostatic charges on non-conducting surfaces, additionally; cleaning of the equipment should be done only with a damp cloth.
6. The YCO14-Y shall be installed in such a way that it is protected against UV radiation and the entry of solid foreign objects or water capable of impairing the safety of the apparatus. Reduce the risk of mechanical damage to a minimum.
7. If the Ex-Link Converter YCO14-Y is installed in Zone 2, the installation must be done in such a way that the pollution degree 2 of the YCO14-Y board is guaranteed.
8. In Zone 2 the „USB Power“ port may not be used.
9. If the cable contains no Ex ic circuits, the cable must be protected against unintended release by use of Sartorius „Strain Relief for USB Cord“ type YSR01 .

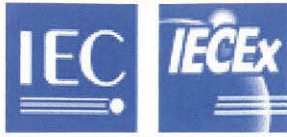

IECEX Certificate of Conformity

Certificate No: IECEX FME 14.0008X

Issue No: 1

Date of Issue: 2016-09-27

Page 4 of 4

DETAILS OF CERTIFICATE CHANGES (for issues 1 and above):

Add YCO14-Y. Correct typing error on drawings 1000011682 and 1000011683.

Sartorius Lab Instruments GmbH & Co. KG
Otto-Brenner-Strasse 20
37079 Goettingen, Germany

Phone: +49.551.308.0
www.sartorius.com

The information and figures contained in these instructions correspond to the version date specified below.

Sartorius reserves the right to make changes to the technology, features, specifications and design of the equipment without notice.

Masculine or feminine forms are used to facilitate legibility in these instructions and always simultaneously denote the other gender as well.

Copyright notice:

This instruction manual, including all of its components, is protected by copyright. Any use beyond the limits of the copyright law is not permitted without our approval. This applies in particular to reprinting, translation and editing irrespective of the type of media used.

© Sartorius Germany

Last updated:
08 | 2018