

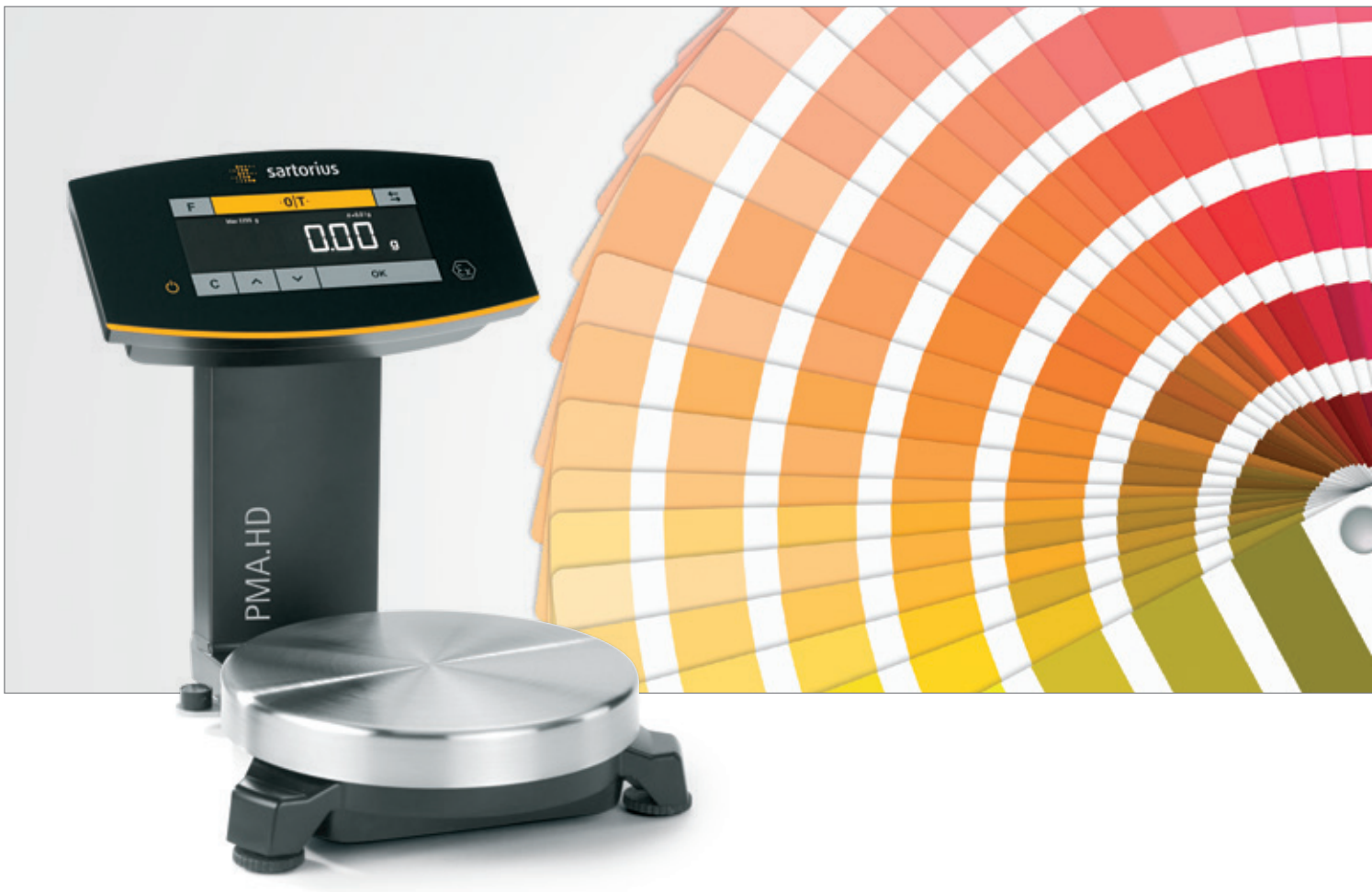

sartorius

PMA.HD

When every drop counts



turning science into solutions

High precision Paint Mixing

The PMA.HD is the ideal solution for Painters and shops where higher accuracy for smaller amounts is needed.

With a high 10 mg resolution, the Ex Zone 1 | Class I, Div. 1 approval and the ability to connect to your color software, the PMA.HD provides the ideal specifications for fast and effective results in your color development lab.

The ergonomic design uses a smaller footprint, saving space, and the superior display and versatile power options make the PMA.HD the ideal solution for your mobile repairs.

Internal Mixing Module

- Integrated mixing module for PC-independent formulation processing

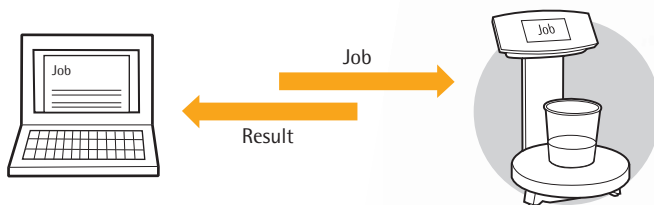

Integrated Applications

- Recalculation functionality in case of over-pouring a component
- Factor calculation to adapt a recipe to any desired can size
- The scale can be calibrated externally with 0.5 kg, 1 kg or 2 kg.

Clean Work Environment



- Plane, solvent-resistant glass display and stainless steel weighing pan for easy cleaning



- Spillage-protected interface at the back of the head



- In-use covers for display to prevent stains





Easy and fast Installation

- Unique one-cable solution for power and data via USB cable
- USB driver is Microsoft® certified for "plug & play" installation
- Stand-alone power setup

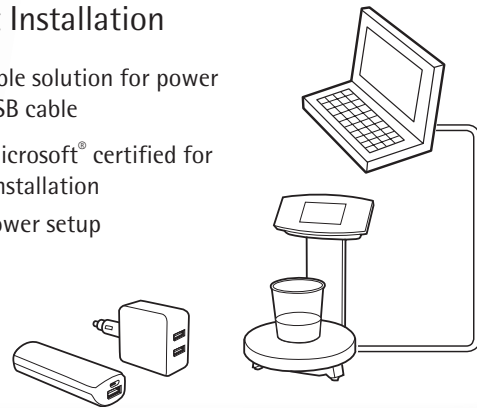

New High-contrast Display



- Wide viewing angle and perfect readability, even from a distance



- Sensor touch with visual feedback



- Bargraph with zoom functionality as dosing assistance | capacity indicator

Enhanced Safety Mechanisms ▷

Compliance with International Regulations ▷

Exclusive PMA.Management Software ▷

Extended Features

Prevention of Unauthorized Usage



- Instant lock function: activated manually by pressing the lock symbol
- Communication lock function: automatic display lock if there is no ongoing communication between scale and PC



- Theft protection with fixation point on the back

Compliance with International Regulations



- Accordance with legal regulations
- Certified as explosion proof



Exclusive PMA.Management Software



- Scale settings easily adjustable with intuitive menu
- Intro text for individualized scale messages (e.g. branding)
- Basic counting application, e.g. for inventory control



sartorius

F

0.00

↕

Max 2200 g

d= 0.01g

0.00 g

⏻

C

↑

↓

OK

Ex

PMA.HD

Functional Accessories

Keep your PMA.HD working like new for the longest time: with covers to protect your scale from paint stains and weights to recalibrate it. See what other useful accessories might be convenient for you.

In-Use covers

In-use cover for display (set of 10)	YCC03PMA10
--------------------------------------	------------



Cables

Link cable to Ex-link converter, length 10 m (32.8 ft.)	YCC01-0052M10
Link cable to Ex-link converter, length 20 m (65.6 ft.)	YCC01-0052M20
Link cable to Ex-link converter, length 30 m (98.4 ft.)	YCC01-0052M30
Grounding cable, 2 m (6.5 ft.)	YCC01-X046M2
USB cable, length 5 m (16.4 ft.)	YCC01-0040M5



Power supply

USB power plug 5 VDC 900 mA	YPS06-USB
AC-adapter set (US, EU, UK)	YAK01
AC- adapter set (AU, ZA, BR)	YAK02
AC- adapter set (IN, KR, CN)	YAK03



Calibration weights

External calibration weight 0.5 kg (class F1)	YCW553-AC-00
External calibration weight 0.5 kg (class F1) with DAKKS certificate	YCW553-AC-02
External calibration weight 1 kg (class F1)	YCW613-AC-00
External calibration weight 1 kg (class F1) with DAKKS certificate	YCW613-AC-02
External calibration weight 2 kg (class F1)	YCW623-AC-00
External calibration weight 2 kg (class F1) with DAKKS certificate	YCW623-AC-02



Technical Data

Metrological data

Capacity	2200 g
Readability	0.01 g
Tare range (subtractive)	-2200 g
Allowable operating temperature	5 ... 40 °C (41 ... 104 °F)
External calibration weight	0.5, 1, 2 kg (class F1 or better)

Dimensions | Weight

Weighing pan (∅)	180 mm
Housing (W×D×H)	212 × 294 × 261 mm
Net weight	approx. 2.1 kg

Power supply

Power supply	via USB 2.0 or higher or power plug YPS06-USB
Input voltage power consumption	5 VDC 2 W
Ex-link converter (Ex zone 1 scale only)	Energy limiting unit included

Approval Ex zone 1 | Class I, Div. 1

IECEX	Ex ib IIB T4 Gb
ATEX	II 2G Ex ib IIB T4 Gb
FM (USA)	IS CL I, DIV 1, GP C,D T4; CL I, Zone 1, AEx ib IIB T4
FM (CAN)	Ex ia CL I, DIV 1, GP C,D T4; Zone 1, Ex ib IIB T4

IP protection

Dust and water protection rating in accordance to EN 60529 IEC 60529:	IP40
---	------

Communication

Data output	USB Type B
Protocol	Sartorius SBI XBPI
Format	7-bit ASCII, 1 Start-bit, 1 or 2 Stop-Bits
Parity	Even, odd, no parity
Transmission rates	1200 to 57,600 Bit/s
Handshake mode	Software, Hardware or None

Internal application	<p>Integrated mixing module for one job</p> <p>Recalculation (correction of over-pours)</p> <p>Calculation by factor (0.25 – 5.0)</p> <p>Stand-alone recipe processing (absolute, additive)</p> <p>Readability switchable to 0.1 g</p> <p>Hardware test and communication symbol</p>
----------------------	--

User interface	<p>High contrast display</p> <p>Sensor touch</p> <p>Bargraph as dosing assistance or capacity indicator</p> <p>Text menu in 12 languages</p>
----------------	--

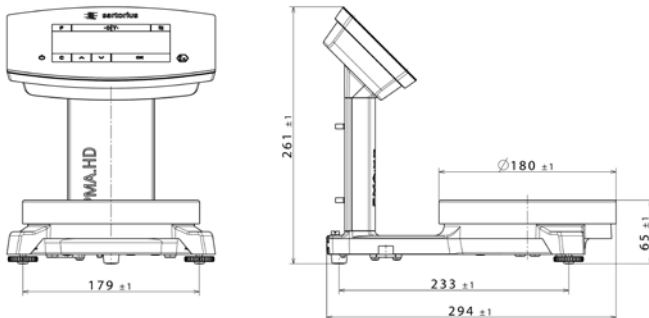

Sales and Service Contacts

For further contacts, visit www.sartorius.com

Europe

Germany

Sartorius Lab Instruments
GmbH & Co. KG
Otto-Brenner-Strasse 20
37079 Goettingen

Phone +49.551.308.0
Fax +49.551.308.3289

France & Suisse Romande

Sartorius France
2, rue Antoine Laurent de Lavoisier
ZA de la Gaudrée
91410 Dourdan

Phone +33.1.70.62.50.00
Fax +33.1.64.59.76.39

Austria

Sartorius Austria GmbH
Modecenterstrasse 22
1030 Vienna

Phone +43.1.7965760.0
Fax +43.1.7965760.24

Belgium

Sartorius Belgium N.V.
Rue Colonel Bourg 105
1030 Bruxelles

Phone +32.2.756.06.90
Fax +32.2.481.84.11

Finland & Baltics

Sartorius Biohit Liquid Handling Oy
Laippatie 1
00880 Helsinki

Phone +358.9.755.951
Fax +358.9.755.95.200

Hungary

Sartorius Hungária Kft.
Kagyló u. 5.
2092 Budakeszi

Phone +3623.457.227
Fax +3623.457.147

Ireland

Sartorius Ireland Ltd.
Unit 41, The Business Centre
Stadium Business Park
Ballycoolin Road
Dublin 11

Phone +353.1.8089050
Fax +353.1.8089388

Italy

Sartorius Italy S.r.l.
Via Torino 3/5
20814 Varedo (MB)

Phone +39.0362.5557.11
Fax +39.0362.5557.99

Netherlands

Sartorius Netherlands B.V.

Phone +31.30.60.53.001
Fax +31.30.60.52.917

info.netherlands@sartorius.com

Poland

Sartorius Poland sp.z o.o.
ul. Wrzesinska 70
62-025 Kostrzyn

Phone +48.61.6473830
Fax +48.61.6473839

Russian Federation

LLC "Sartorius RUS"
Vasilyevsky Island
5th line 70, Lit. A
199178 St. Petersburg

Phone +7.812.327.53.27
Fax +7.812.327.53.23

Spain & Portugal

Sartorius Spain, S.A.
Avda. de la Industria, 32
Edificio PAYMA
28108 Alcobendas (Madrid)

Phone Spain +34.913.586.095
Phone Portugal +351.800.855.800
Fax Spain +34.913.589.623
Fax Portugal +351.800.855.799

Switzerland

Sartorius Mechatronics Switzerland AG
Ringstrasse 24a
8317 Tagelswangen (ZH)

Phone +41.44.746.50.00
Fax +41.44.746.50.50

U.K.

Sartorius UK Ltd.
Longmead Business Centre
Blenheim Road, Epsom
Surrey KT19 9QQ

Phone +44.1372.737159
Fax +44.1372.726171

Ukraine

LLS "Sartorius RUS"
Post Box 440 "B"
01001 Kiev, Ukraine

Phone +380.44.411.4918
Fax +380.50.623.3162

Americas

USA

Sartorius Corporation
5 Orville Drive, Suite 200
Bohemia, NY 11716

Phone +1.631.254.4249
Toll-free +1.800.635.2906
Fax +1.631.254.4253

Argentina

Sartorius Argentina S.A.
Int. A. AVALOS 4251
B1605ECS Munro
Buenos Aires

Phone +54.11.4721.0505
Fax +54.11.4762.2333

Brazil

Sartorius do Brasil Ltda
Avenida Senador Vergueiro 2962
São Bernardo do Campo
CEP 09600-000 - SP- Brasil

Phone +55.11.4362.8900
Fax +55.11.4362.8901

Canada

Sartorius Canada Inc
1173 North Service Road West, D4
Oakville, ON L6M 2V9

Phone +1.905.569.7977
Toll-Free +1.800.668.4234
Fax +1.905.569.7021

Mexico

Sartorius de México, S.A. de C.V.
Libramiento Norte de Tepetzotlan s/n,
Colonia Barrio Tlacateco,
Municipio de Tepetzotlan,
Estado de México,
C.P. 54605

Phone +52.55.5562.1102
Fax +52.55.5562.2942

leadsmex@sartorius.com

Peru

Sartorius Peru S.A.C.
Avenue Alberto del Campo 411
Floor 12 - The Office
15076 - San Isidro, Lima

Phone +51.1.441 0158
Fax +51.1.422 6100

Asia | Pacific

Australia

Sartorius Australia Pty. Ltd.
Unit 5, 7-11 Rodeo Drive
Dandenong South Vic 3175

Phone +61.3.8762.1800
Fax +61.3.8762.1828

China

Sartorius (Shanghai) Trading Co., Ltd.
3rd Floor, North Wing, Tower 1
No. 4560 Jinke Road
Zhangjiang Hi-Tech Park

Hong Kong

Sartorius Hong Kong Ltd.
Unit 1012, Lu Plaza
2 Wing Yip Street
Kwun Tong
Kowloon, Hong Kong

Phone +852.2774.2678
Fax +852.2766.3526

India

Sartorius Weighing India Pvt. Ltd.
#69/2-69/3, NH 48, Jakkasandra,
Nelamangala Tq
562 123 Bangalore, India

Phone +91.80.4350.5250
Fax +91.80.4350.5253

Japan

Sartorius Japan K.K.
4th Fl., Daiwa Shinagawa North Bldg.
8-11, Kita-Shinagawa 1-chome
Shinagawa-ku, Tokyo, 140-0001 Japan

Phone +81.3.3740.5408
Fax +81.3.3740.5406

Malaysia

Sartorius Malaysia Sdn. Bhd
Lot L3-E-3B, Enterprise 4
Technology Park Malaysia
Bukit Jalil
57000 Kuala Lumpur, Malaysia

Phone +60.3.8996.0622
Fax +60.3.8996.0755

Singapore

Sartorius Singapore Pte. Ltd
10 Science Park Rd
The Alpha #02-13/14
Singapore Science Park II
Singapore 117684

Phone +65.6872.3966
Fax +65.6778.2494

South Korea

Sartorius Korea Ltd.
8th Floor, Solid Space B/D,
PanGyoYeok-Ro 220, Bundang-Gu
SeongNam-Si, GyeongGi-Do, 463-400

Phone +82.31.622.5700
Fax +82.31.622.5799

Thailand

Sartorius (Thailand) Co. Ltd.
129 Rama 9 Road,
Huaykwang
Bangkok 10310

Phone +66.2643.8361-6
Fax +66.2643.8367



◀ www.sartorius.com/paintmixing