

Operating Instructions

Sartobind[®] Phenyl

Void Volume Optimized Capsules and Cassettes
With 8 mm Bed Height



8 mm: nano
3 mL

150 mL

400 mL

800 mL

1.2 L

Jumbo 5 L

Cassette 1.6 L

1000032236



SARTORIUS

Read operational instructions carefully before using Sartobind capsules.

⚠ Use of the products in applications not specified or not described in this manual, may result in improper function, personal injury, or damage of the product or material. The products are supplied as non-sterile unless otherwise expressly described. The membrane is dried from glycerol.

⚠ Die Verwendung dieser Produkte für Anwendungen, für die sie nicht bestimmt oder nicht in dieser Anleitung beschrieben sind, können zu einer schlechteren Funktion, Zerstörung der Produkte oder sogar zu Verletzungen von Mensch und Material führen. Die Produkte sind nicht steril sofern dies nicht ausdrücklich anders beschrieben ist. Die enthaltene Membran wird aus Glycerin getrocknet.

- ⚠ L'utilisation des produits pour des applications non-spécifiées ou décrites dans ce manuel peut causer un dysfonctionnement, une destruction du produit, des dommages matériels ou même corporels. Les produits sont fournis non-stériles, sauf indication contraire expressément mentionnée. La membrane est séchée avec de la Glycérine.

- ⚠ La utilización de este producto en aplicaciones ajenas o no establecidas en el manual de operación, puede provocar un mal funcionamiento del producto, del material, así como daños personales. Los productos suministrados no son estériles a menos que se describa lo contrario. La membrana ha sido secada de glicerina.

 把产品用于手册中没指定或描述的应用, 可能导致产品失效, 人员受伤, 或使产品及物料受损。囊式膜柱以非灭菌的形式供应。膜用甘油脱水。

 当製品を該当しない用途、あるいは当製品取扱説明書に記載されていない応用分野において使用した場合、当製品の機能上の不具合や損傷、人体への危害、あるいは他の物品の損傷を招く恐れがあります。特に明記のない場合、当製品は滅菌処理されていません。当メンブレンはグリセリンを用いて乾燥させてあります。

Intended use

The membrane chromatography products also described as membrane adsorbers are intended and validated for single use to avoid carryover as well as tedious and costly cleaning validation procedure. However it is technically possible to reuse after cleaning in place depending on application, character of sample and process. Additional cleaning and validation steps will be needed to assure constant binding capacity and flow rate after each cycle.

Sartobind nano 3 mL capsules have been developed for working with small sample volumes. They are perfect for small scale applications, and also for screening purposes and laboratory-scale bind & elute and flow-through purifications.

Sartobind 150 mL capsules have been developed for intermediate and pilot scale in the downstream processing of therapeutic proteins for the removal of hydrophobic contaminants or bind and elute purifications.

Sartobind 400 mL up to Jumbo 5 L capsules have been developed for production purposes in the biopharmaceutical industry.

Sartobind 1.6 L cassettes are used in the Pilot Scale Filter Holder of up to 20.8 L membrane volume for the biopharmaceutical production.

Table of Contents

1	Storage Conditions	10
2	Introduction	11
3	Technical Data	18
4	Materials	20
5	Binding Capacity	21
6	Installation	22
7	Operation	26
7.1	Venting	26
7.2	Cleaning and equilibration	28
7.3	Recommended flow rates and equilibration buffer volumes	28
7.4	Buffer conditions	30
7.5	Selection of pH conditions and temperature	32
7.6	Contaminant removal from proteins in flow-through mode	32

7.7	Sample preparation.....	32
7.8	Washing	33
7.9	Elution.....	33
7.10	Draining	33
7.11	Regeneration and Storage.....	34
7.12	Chemical stability.....	34
7.13	Operation of the Sartobind nano with peristaltic pumps or liquid chromatography (LC) systems.....	35
7.14	Scaling up.....	35
8	Integrity Test by Diffusion	39
8.1	Installation for test.....	39
8.2	Operation of test	40
9	Troubleshooting	45
10	Quality Assurance	50

11	Ordering Information	51
11.1	Products.....	51
11.2	Accessories.....	52
12	Dimensions and Connections	54

1 Storage Conditions

Keep the Sartobind capsules and cassettes until use in the transport box at room temperature in a clean, dry and dark place. When not in use, the end caps of the nano should be attached to the units to avoid oxygen all the times. The sealed bag of the products should not be opened unless you use it. These products are mainly for single use applications. However, it is technically possible to reuse. Then, after use store the cleaned capsules in 20% ethanol in the dark at +2 to +8°C.

2 Introduction

The capsules and cassettes with 8 mm bed height are hydrophobic interaction chromatography (HIC) devices based on macroporous membranes. They can be used for chromatographic separations in the downstream processing of viruses and proteins. The hydrophobic ligand is coupled to a membrane which is fitted into a plastic housing for quick handling, making HIC purification nearly as easy as filtration. The devices are constructed with optimized fluid channels. The capsules carry a central core and the cassettes a spacer element to minimize void volume. To set up and operate the Sartobind Jumbo we recommend the Jumbo trolley (see chapter "11.2 Accessories", page 52).

These products are mainly for single use to avoid carryover as well as tedious and costly cleaning validation procedures. However, it is technically possible to reuse after cleaning in place (see also section "7.11 Regeneration and Storage", page 34). They are validated for contaminant removal from proteins in flow-through mode (negative chromatography) in single use, to bind e.g. aggregates or other hydrophobic contaminants. The capsules can also be used to capture proteins.

Hydrophobic interaction chromatography separates and purifies biomolecules based on differences in their hydrophobicity.

The phenyl membrane adsorber follows the same rules known from the conventional hydrophobic interaction chromatography. Due to the large pore size, membrane adsorbers show excellent flow properties.

Buffers with high concentrations of salt promote the adsorption of proteins on the hydrophobic membrane matrix. The effect of anions and cations on protein precipitation is described in the Hofmeister series:

Anions: PO_4^{3-} , SO_4^{2-} , $\text{CH}_3\text{-COO}^-$, Cl^- , Br^- , NO_3^- , ClO_4^- , I^- , SCN^-

Cations: NH_4^+ , K^+ , Na^+ , Cs^+ , Li^+ , Mg^{2+} , Ca^{2+}

Increasing precipitation
Salting out effect
Stronger binding

Increasing chaotropic
Salting in effect
Weaker binding

Typically ammonium sulfate containing salting-out buffers are used to promote ligand-protein interaction. With increased concentration more protein is bound until the protein precipitates. Preferably, the protein binding is performed in the region where the amount of bound protein increases linearly with the salt concentration. Proteins are eluted by decreasing the salt concentration in the elution buffer. Using step or linear gradient elution proteins are eluted in the order of their hydrophobicity.

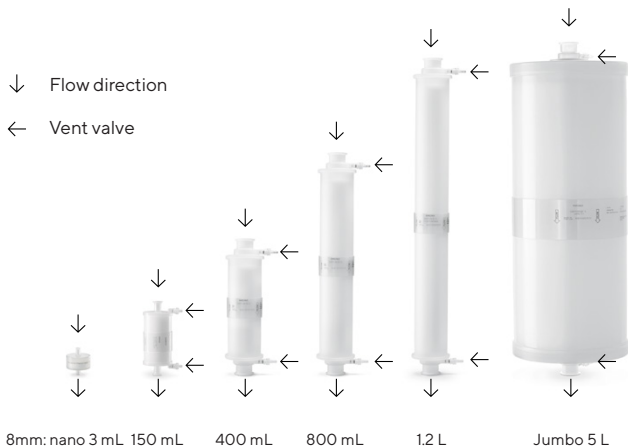
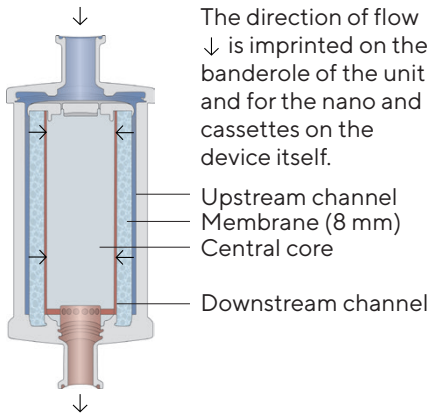

Fig. 1: Flow direction and position of vent valves of 8 mm capsules

⚠ Capsules should be visually inspected before use. In case of visible damage, the capsule must be replaced. Close vent valves before use by screwing the valve clockwise.



Fig. 2: Flow direction and position of vent valve connection of 8 mm cassettes



The direction of flow ↓ is imprinted on the banderole of the unit and for the nano and cassettes on the device itself.

Upstream channel
Membrane (8 mm)
Central core
Downstream channel

Fig. 3: Construction and flow path inside of the capsules

For the nano and 150 mL devices the central core is made from a solid polypropylene cylinder. For the larger capsules it is made from a self-contained air filled polypropylene cylinder. The interior of the core is inaccessible for gases and fluids. The two flat membrane stacks of the cassettes are separated by a central spacer element.



Fig. 4: Side view cassette; rectangle cutaway section see Fig. 5

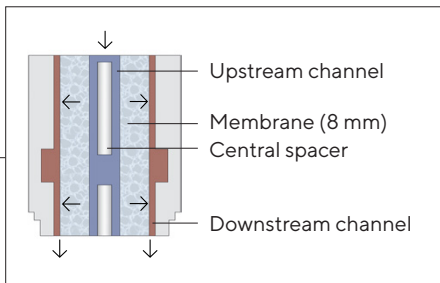

Fig. 5: Construction and flow path inside the 8 mm cassette

3 Technical Data

Membrane volume (MV)	3 mL	150 mL
Nominal membrane area	110 cm ²	5,500 cm ²
Bed height	8 mm	8 mm
Design	Cylindrical	Cylindrical
Sartobind Phenyl typical 10% dynamic binding capacity*	44 mg	2.2 g
Maximum pressure bar (MPa, psig) at 20°C	4 (0.4, 58)	4 (0.4, 58)
Maximum pressure during venting bar (MPa, psig) at 20°C	-	0.5 (0.05, 7)
Nominal void volume (mL)	4	200
Nominal void volume (MV)	1.3	1.3
Approximate weight	10 g	400 g

1 mL membrane = 36.4 cm² membrane

Ion capacity per cm² of membranes: 3 µeq

Short term pH stability Phenyl: 2-14 refers to cleaning in place and regeneration procedures during operation

400 mL	800 mL	1.2 L	5 L	1.6 L
14,600 cm ²	29,000 cm ²	44,000 cm ²	182,000 cm ²	58,000 cm ²
8 mm	8 mm	8 mm	8 mm	8 mm
Cylindrical	Cylindrical	Cylindrical	Cylindrical	Flat sheet
5.9 g	11.7 g	17.6 g	72.8 g	23.2 g
4 (0.4, 58)	4 (0.4, 58)	4 (0.4, 58)	3 (0.3, 43.5)	2 (0.2, 29)
0.5 (0.05, 7)	0.5 (0.05, 7)	0.5 (0.05, 7)	0.5 (0.05, 7)	0.5
540	1,080	1,600	7,000	2900
1.4	1.4	1.3	1.4	1.8
760 g	1.3 kg	1.9 kg	16 kg 20 kg wet 23 kg filled	4.9 kg 6.0 kg wet

Long term storage pH stability Phenyl: 3-13 refers to overnight storage and longer. Preferably store units in 20% ethanol | buffer

* See section "5 Binding Capacity", page 21

4 Materials

Membrane materials

Matrix	Stabilized reinforced cellulose
--------	---------------------------------

Membrane thickness membrane volume = membrane area	275 μm 1 mL = 36.4 cm^2
---	---

Nominal pore size	> 3 μm
-------------------	-------------------

Hydrophobic interaction ligand	HIC: Phenyl (R-NH-C ₆ H ₅)
--------------------------------	---

Capsule materials

Outer cage, inner core, end caps, capsule housing, nonwoven, fleece	Polypropylene
--	---------------

O-ring in vent valve (except nano)	EPDM (ethylene propylene diene monomer)
------------------------------------	--

Cassette materials

Outer cage, seal, nonwoven, fleece	ABS, silicone, polyethylene, stable to gamma irradiation
------------------------------------	---

5 Binding Capacity

Data are based on dynamic binding capacity measurements 10% using 3 layers of 5 cm² membrane discs (15 cm² total area, membrane thickness of 275 μm) arranged in a holder and run at 10 mL/min.

Typical dynamic binding capacity 10%	Reference protein and buffer
0.4 mg/cm ² (14.6 mg/mL)	Polyclonal IgG (1 mg/mL) 0.9 M (NH ₄) ₂ SO ₄ in 50 mM potassium phosphate, pH 7.5

6 Installation

The contents of the package are described in chapter “11.1 Products”, page 51. When unpacking capsule, protect inlet and outlet connectors from damage. Never keep or place the capsule directly on the floor on the connectors. This might damage the sanitary adapters.

For unpacking of Jumbo 5 L capsule, take the capsule including the styrene foam end protectors, out of the box and place it upright on the end protectors.

Move the Jumbo trolley (accessory) in place. Then remove upper foam protection and transparent bag. Lift the Jumbo directly onto the trolley (inlet is up and the arrow imprinted on the banderole is pointing down). We recommend to connect the Jumbo with the trolley by the three screws delivered with the trolley. To ensure safe unpacking, the protective caps on inlet and outlet should stay until you use the unit. The Jumbo 5 L carries protective caps on vent valves as well. Remove before venting.

The capsules and cassettes should be installed in an upright position in the process flow. In this position the inlet is up. The flow is guided to the upstream channel (i.e. the solution enters the device) passing through the membrane layers to a downstream channel and to the outlet of the device (see Fig. 3). Install the capsule and cassette(s) in-line with a prefilter (0.2 μm or 0.45 μm) in front of the device to prevent blockage or pressure build-up.

For using the cassettes you need an appropriate cassette holder and one Manifold Set (see chapter "11.2 Accessories", page 52). Before use you must read the Pilot Filter Holder manual, order no. 85037-547-72 or Process | Double Process Filter holder manual order no. 85037-553-19. If you plan to use a different filter holder from other manufacturers, you have to contact your nearest Sartorius office for technical directions.

Unpack the Manifold Set containing one inlet and one outlet connection plate. Place the “INLET” marked plate at one end of the holder. “THIS SIDE UP” is readable on top. Place the “OUTLET” marked plate at the other end of the holder, again “THIS SIDE UP” is readable from the top. The fluid channels of both plates are oriented to each other.

⚠ The cassettes must be oriented in the lowest possible position in the holder otherwise the system may leak. The cassettes must have the same lot number.

Put the desired number of Sartobind cassettes between the manifolds (see Fig. 6). Provided “THIS SIDE UP” is readable the cassettes are correctly installed.

The maximum clamping force for 1 – 13 cassettes with Pilot and Process holders before start of use is: 25 kilonewton or kN (200 bar, 2900 psig) for installed 12.6 cm² piston area. Now close all DRAIN and VENT valves of the manifold plates by the pinch clamp manually.

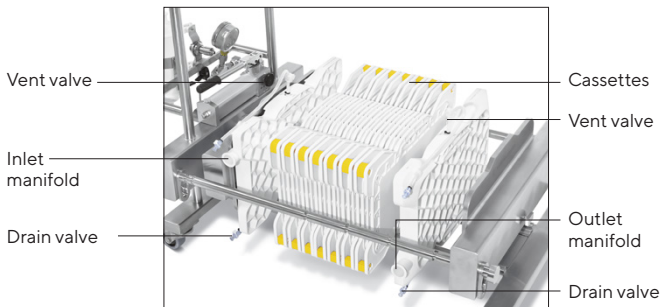

Fig. 6: Insert cassette(s) between the manifold inlet and outlet plates on the Pilot Filter Holder.

Connect the inlet and outlet plates with 1½ inch tri-clamp to the process solution. Maximum pressure for the set-up of 1 to 13 cassette(s) is 2 bar (0.2 MPa, 29 psig). Make sure that pump peak pressure caused by pulsation stays below this limit too.

7 Operation

7.1 Venting

It is important to remove air from the unit completely.

All capsules except nano carry vent valves (see Fig. 1). The vent valves are equipped with hose barb connectors for the fluid spilled out during venting. After unpacking check vent valve position. When turning anticlockwise, the valve is open, when turning clockwise, the valve is closed. Before opening the vent valve, please connect the valves with flexible tubing (inner diameter 6 mm) to waste. During venting of capsules please do not exceed 0.05 MPa (0.5 bar | 7.3 psi) pressure, as the vent valve O-ring could change its position which will result in insufficient closing of the valve. For appropriate venting, open the vent valve screw $\frac{1}{3}$ turn to left until all air is replaced by fluid. For venting the cassettes, tubes with quick connectors are attached to the inlet and outlet manifolds and closed by a pinch clamp.

For the nano 3 mL capsule fill a 10–20 mL Luer syringe with equilibration buffer and connect to the capsule, then hold capsule upright (outlet is up) and expel air as shown in Fig. 7. If you still detect any air in the filled unit, close it at the outlet, hold the syringe up and move the plunger slightly up and

down that air bubbles can ascend into the syringe. Another method is to connect a second empty syringe to the top of the nano and expel air and buffer into that syringe, disconnect the upper syringe to push out air and reconnect to the nano, turn it and purge the solvent back and forth. Very small air bubbles observed directly below the inlet do not disturb separations. The capsules will function normally as long as the small air bubbles remain outside of the membrane bed.

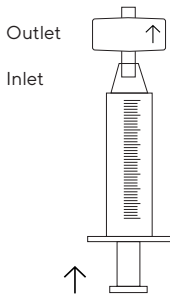

Fig. 7: Filling the Sartobind nano with a Luer syringe

7.2 Cleaning and equilibration

The devices have to be cleaned in place directly before use with 1 N NaOH, 30 min at 20°C. Preferentially work at room temperature as low temperature increases viscosity of solvents. Also cold NaOH can induce swelling of the cellulose matrix and significantly reduce flow rate.

1. For sanitization use 30 membrane volumes (MV) of 1 N NaOH solution at a flow rate of 1 MV/min.
2. Flush with 25 MV of water at 5 MV/min.
3. Flush with 10 MV of equilibration buffer at 5 MV/min.







7.3 Recommended flow rates and equilibration buffer volumes

Membrane adsorbers can be run at much higher flow rate per volume than resin columns. The recommended flow rate for membrane adsorbers with 8 mm bed height is 5 membrane volumes per minute. This recommendation is only a guideline since buffers and samples have different compositions and viscosities. Please test your planned flow rates using a small scale device to ensure that they fit into your pump capacities and device pressure limits. Lower flow rates than the recommended ones can also be used but will typically not improve binding

capacity or overall performance. Cold room temperature increases buffer viscosity and possibly back pressure.

The equilibration buffer volume is typically 10 membrane volumes depending on the type of buffer.

For the cassettes, flow rate and equilibration volumes have to be multiplied with the number of cassettes in use.

							
Membrane volume (MV)	3 mL	150 mL	400 mL	800 mL	1.2 L	5 L	1.6 L
Rec. flow rate (L/min)	0.015	0.75	2	4	6	25	8**
Rec. equilibration volume* (L)	0.03	1.5	4	8	12	50	16**

* Refer to 7.2 Cleaning and equilibration

** Multiply with number of used cassettes

7.4 Buffer conditions

Proteins are bound to the phenyl membrane at salt concentrations typically above 400 mM. Larger proteins or monoclonal antibody aggregates tend to bind above 200 mM ammonium sulphate concentrations. This allows for the removal in flow-through mode to save matrix cost. Differences in protein hydrophobicity have influence on the choice of salt concentration. The strength of the interaction depends mainly on salt concentrations but also on the number of exposed hydrophobic groups of the sample and on membrane ligand type and density. Sample properties, temperature, type and pH as well as additives influence the binding process as well. The character of the binding buffer will decide the success of the separation. It is therefore important to optimize the equilibration | start buffer with respect to pH, type of solvent and salt concentration.

Binding buffer examples

To bind IgG	0.8 M $(\text{NH}_4)_2\text{SO}_4$ in 50 mM potassium phosphate, pH 7.5
To bind bovine serum albumin or lysozyme	2 M $(\text{NH}_4)_2\text{SO}_4$ in 50 mM potassium phosphate, pH 7.0

Choose salt concentrations as low as possible to bind the protein. Higher salt concentrations may result in precipitation.

Commonly used salts	Remarks
$(\text{NH}_4)_2\text{SO}_4$	Typical choice, often best results, not stable at >pH 8
Na_2SO_4	Solubility of proteins reduced
NaCl	3-4 M needed
KCl	No special remarks
$\text{CH}_3\text{COONH}_4$	No special remarks

7.5 Selection of pH conditions and temperature

The effect of pH on binding is much less than in ion exchange chromatography. Higher temperature typically promotes stronger binding of the sample solute as known from entropy driven reactions. Thus temperature control is important to achieve reproducible results.

7.6 Contaminant removal from proteins in flow-through mode

The loading conditions should be chosen to selectively retain contaminants with higher hydrophobicity and allow the target molecule as the monomeric antibody for example with less hydrophobicity to pass through the membrane adsorber.

7.7 Sample preparation

The sample should be adjusted to the starting buffer and be prefiltered through a 0.2 μm membrane e.g. Sartopore® capsule. For small volumes in the mL range use a 0.2 μm Minisart® filter with Luer outlet (order number 16532-K for polyethersulfone or 16534-K for cellulose acetate membrane).

⚠ Unfiltered feed will block the Membrane Adsorber and lead to capacity loss and increased back pressure. We recommend inline filtering during operation. With increase of pressure replace filter and restart.

7.8 Washing

When using capsules in bind & elute mode, wash with equilibration buffer after sample loading.

7.9 Elution

To elute the target protein use buffers with salt typically below 100 mM.

7.10 Draining

You may drain the capsule or cassette by application of air or nitrogen pressure (<1 bar |14.5 psi) to the inlet of the device.

⚠ A dual air regulator system is recommended to prevent over-pressurization of the Sartobind devices. The first regulator should reduce line air pressure to 2 bar. The second regulator, positioned immediately upstream of the Sartobind, should reduce the 2 bar regulated supply pressure to the <1 bar (14.5 psi) for a capsule and 0.5 bar (7.3 psi) for 1 up to 13 cassettes draining pressure.

7.11 Regeneration and Storage

After use, regenerate with e.g. 50% ethylene glycol, 70% ethanol or 30% isopropanol in pure water, wash extensively with pure water and 20% ethanol and store airtight in 20% ethanol at +2 to +8°C in a dark place. Do not store in high salt solution.

7.12 Chemical stability

The devices are stable against all commonly used buffers, ethanol and isopropanol. They can be cleaned with 1 N NaOH or 1 N HCL. Do not use oxidizing agents.

7.13 Operation of the Sartobind nano with peristaltic pumps or liquid chromatography (LC) systems

After the unit is filled completely with equilibration buffer, close the outlet of the Sartobind nano and remove the syringe. Start your LC system or peristaltic pump at a low flow rate. When fluid emerges, stop the pump, connect the tubing to the inlet of the Sartobind nano. Make sure that no air is introduced. Remove the cap from outlet. Run the pump until fluid emerges from the outlet of the unit and stop it. Then connect the outlet of the unit via Luer adapter to the LC detector and proceed with loading. If your system pressure is too high, refer to your LC system manual to remove any flow restrictor after the UV cell, as the system may generate a pressure above the allowed maximum pressure. As membrane adsorbers run typically at much higher flow rates than columns, there is no risk of bubble formation in the UV cell when removing the restrictor.

7.14 Scaling up

Complete break through experiments for the target compound to be bound on the membrane matrix. After optimization of binding conditions, the purification step can be scaled up to a larger capsule.

Recommendations:

Maintain

- Bed height (automatically kept constant when using capsules with 8 mm bed height)
- Linear flow (automatically kept constant when using capsules with 8 mm bed height)
- Sample concentration

Increase (see scaling factors in the following table)

- Sample loading volumes
- Volumetric flow rate
- Membrane volume

Scale up calculations are done preferably by keeping the bed height and changing the membrane volume as the calculation is most simple. Other methods for scale up via residence time will lead to similar result. The residence time is the membrane volume divided by the flow rate. Using the Sartobind nano 3 mL the scale up factor for flow rate and binding capacity is equal to a multiplication factor of membrane volumes of the listed scale up devices:

Size	Membrane volume [mL]	Factor to increase* (from nano)
nano	3 mL	-
5"	150 mL	50
10"	400 mL	133
20"	800 mL	266
30"	1.2 L	400
Jumbo	5 L	1,667
Cassette	1.6 L	533
Cassettes**	20.8 L	6,933

* Flow rate and binding capacity;

** 13 Cassettes as example

Example: After breakthrough experiments with the nano, you realize that a 1500-fold binding capacity is needed for a large scale run. You will choose the 5 liter Jumbo capsule. To determine the running conditions of the Jumbo and to keep consistent upscaling, increase flow rate by a factor of ~1670. To assure the scale up, additional experiments with the 150 mL device (increase by a factor of 50) support this scale up calculation.

In the example above 1 and 13 cassettes are used, but any number of cassettes between one or 13 which is the maximum in the pilot filter holder can be applied. Then the factor to increase is adapted proportionally. For a larger scale above 20 L, a process and a double process filter holder is available as accessory (see chapter "11.2 Accessories", page 52).

To assure the scale, intermediate sizes are recommended to assure the design.

⚠ Keep sample concentration constant in lab and production scale. Watch out for volumes in the piping and flow rates in the whole system.

8 Integrity Test by Diffusion

The integrity of a membrane adsorber can be controlled by a diffusion test.

The testing procedure describes the diffusion test for pre and post use. The test is intended to discriminate between defective and intact devices and to detect major bypasses, large holes and faulty assembly.

8.1 Installation for test

Test procedure has been generated with current Sartocheck® instrument family e.g. Sartocheck® 4 plus (26288), 4 (16288) or 3 plus (16290). Use of earlier Sartocheck® instruments will generate faulty data. Install adsorber as shown in Fig. 8.

Please note that the test procedure with other vendor's integrity testers can require a different set up.

8.2 Operation of test

8.2.1 Pre-washing of device

Pre-wash with 30 membrane volumes of equilibration buffer as a testing solvent, otherwise use water for pre-wetting the membrane.

 The capsule needs to be pre-washed with the testing solvent, to remove any glycerol. The washing solution should be at room temperature. Keep the unit in an upright position for proper venting and open the vent screw on top of the device until all air is replaced by testing solvent.

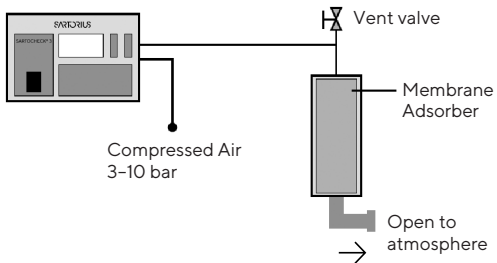

Fig. 8: Set up of diffusion test with Sartocheck® 4 Plus, 4 or 3 Plus

8.2.2 Diffusion measurement with Sartocheck® 4 Plus

- Choose **Programming** in the main menu
- Choose **Diffusion Test**

Choose the test pressure, stabilization and testing time for your device from the table. If you set the Net Volume to zero, Sartocheck® automatically measures the upstream void volume including tubing.

Test parameters

Size	Bed height (mm)	Membrane volume (MV)	Test pressure mbar (psi)	Stabilisation time (min)	Testing time (min)	Diffusion max. mL/min
nano	8 mm	3 mL	200 (2.9)	2	1	-
5"	8 mm	150 mL	200 (2.9)	2	1	15
10"	8 mm	400 mL	200 (2.9)	3	1	15
20"	8 mm	800 mL	200 (2.9)	3	1	15
30"	8 mm	1.2 L	200 (2.9)	3	1	15
Jumbo	8 mm	5 L	200 (2.9)	5	1	15
Cassette(s)*	8 mm	1.6 - 20.8 L	200 (2.9)	5	1	15 - 195

* Diffusion max. per 8 mm cassette is 15 mL/min multiplied by number of cassettes

8.2.3 Results and evaluation

- Diffusion \leq Diffusion max.:
Test passed
(diffusion value on the print out)
- Diffusion $>$ Diffusion max.:
Test failed
(red text on the print out)

The maximum allowed diffusion values are per device. If you set up for example 10 cassettes in a holder the values have to be added up and the max diffusion value will be 150 mL.

9 Troubleshooting

Problem	Possible cause	Action
Air bubbles can be seen	Incomplete air removal	Small air bubbles seen in the top of the unit do not interfere with the purification as long as they do not touch the membrane bed. If too much air is enclosed, repeat removal as described in chapter "7.1 Venting", page 26.
I installed the capsule upside down	Installation of capsule may be easier in the process flow	Validation has been done with a process flow from top to bottom. Thus it is clearly recommended to use capsules in the described flow direction (Feed enters capsule on top and leaves it on bottom).
I deviated from the CIP and flushing equilibration procedure		The capsules have been qualified and validated according to the given procedure. If a deviation is necessary, the results may also deviate from the given validation data.
High back pressure	Material has not been filtered	Pre-filter with 0.2 µm or 0.45 µm filter before processing through the unit (preferentially inline).

Problem	Possible cause	Action
High back pressure	Material has been filtered but was stored before purification	Proteins can form aggregates within hours or during operation. Thus we recommend to prefilter inline by attaching a 0.2 μm filter in front of the adsorber. When you observe again pressure built up, replace the filter.
	LC system generates high pressure	Remove restrictor after the UV cell.
	The adsorber is clogged membrane fouling	Replace unit. Perform a regeneration cycle. You may backflush within given flow and pressure limits, perform a regeneration cycle.
	Viscosity swelling effects	Work at room temperature, avoid lower temperatures
Target molecule is not bound	Conditions for binding are insufficient	Increase salt concentration, control other process parameters as type of salt, pH and temperature.

Problem	Possible cause	Action
Binding capacity is not sufficient	Process conditions not optimized	Use larger adsorber device, or: connect two adsorbers (same size) in series (i.e connect outlet of first adsorber to inlet of second) to achieve higher binding capacity. As a rule of thumb the pressure doubles when the flow rate is kept constant and the number of membrane layers is doubled.
Reuse is needed	For economic or practical reasons	The major application of Sartobind capsules is the single use and they are constructed in plastic housing for this. Also they are validated and certified only for one use. Technically they can be reused. The durability of the unit depends on the nature of sample and sample preparation, prefiltration as well as proper regeneration and application. Plastic materials and membranes allow CIP and long term storage if carefully treated. For reuse validation we assist you with our Validation Service. Please ask your local representative.

Problem	Possible cause	Action
Binding capacity decreases after several uses	Improper filtration	Pre-filter with 0.2 µm filter before processing through the unit.
	Some molecule species binds tightly and cannot be removed with 1 N NaOH 1 h	Use capsule only once.
	Protein or contaminants are still bound from last cycle	Perform a regeneration cycle (see "7.11 Regeneration and Storage", page 34).
	Wrong storage	Do not store in high salt solution. Do not use oxidative chemicals in buffers.
Change of membrane color	Wrong storage	No action. A slight change of membrane's color is due to oxygen and light exposure of the membrane and does not affect adsorptive properties of the membrane or performance of the device.

Problem	Possible cause	Action
A vertical line is seen on one capsule side when filled	Membrane edge visible	No action necessary. It can be visible the edge of the fleece touching the inner tube.
I purged with air or nitrogen and lost flow and binding capability.	Air has entered into the pores	See troubleshooting “Applied bubble point instead of diffusion test” below.
Accidentally a bubble point test instead of diffusion test has been run	Operation error	The membrane has then to be purged extensively to remove all the air which has been pressed into the pores. If properly purged, the diffusion test can be run successfully and the device works as expected.
Cassettes system leaks or fails at integrity test	Wrong assembly	Position manifolds and cassettes at the lowest position in the holder otherwise seals are not perfectly aligned.

10 Quality Assurance

This product is tested for protein dynamic binding capacity and flow rate. Sartobind membranes have been tested for protein dynamic binding capacity, flow rate, thickness, and evenness. Capsules and membranes are manufactured in a controlled environment. The product meets all Sartorius Stedim Biotech standards for traceability, production and specifications as given here or exceeded them as certified in the quality assurance certificate enclosed. A validation and an extractables guide are available on request.

11 Ordering Information

11.1 Products



Order number	Description	Quantity
96HICP42EUC11--A	Sartobind Phenyl nano 3 mL, Luer female connectors, 2 PEEK adapters Luer male to UNF 10-32 female, manual, certificate	4
96HICP42E9BFF	Sartobind Phenyl 150 mL, ¾" sanitary clamp, manual, certificate	1
96HICP42E1HSS	Sartobind Phenyl 400 mL, 8 mm, 1½" sanitary clamp, manual, certificate	1
96HICP42E2LSS	Sartobind Phenyl 800 mL, 8 mm, 1½" sanitary clamp, manual, certificate	1
96HICP42E3FSS	Sartobind Phenyl 1.2 L, 8 mm 1½" sanitary clamp, manual, certificate	1
96HICP42E3ESS	Sartobind Phenyl Jumbo 5 L, 8 mm 1½" sanitary clamp, 2 protective caps, manual, certificate	1
98HICP42E-P	Sartobind Phenyl Cassette 1.6 L, 8 mm, 1½" sanitary clamp via manifold set (accessory), manual, certificate	1

11.2 Accessories

Order number	Description	Quantity
1ZA---0004	Adapter Luer male to UNF 10 – 32 female, PEEK	1
1ZAOGV0003	Adapter UNF 10 – 32 female to sanitary ¾", 25 mm, polyoxymethylene	2
5ZGI--0001	Holder for 1 × 200 to 1,200 mL (10 – 30") capsule, stainless steel, 3 legs	1
5ZALB-0002	Distribution adapter for 3 × 200 (10 – 30") to 1200 mL capsules, 1 × 2", 3 × 1½", sanitary, stainless steel	1
7ZAL-V0013	Reducing adapter 1½" (50.5 mm) to ¾" (25 mm), sanitary	1
7ZAL-V0010	Reducing adapter 2" (64 mm) to 1½" (50.5 mm), sanitary	1
9ZGL--0102	Trolley for Jumbo 2.5 or 5 L, stainless steel	1
16290	Sartocheck 3 Plus Integrity Tester	1
26288---FT	Sartocheck 4 Plus Filter Integrity Tester	1

Order number	Description	Quantity
29Z-S00001	Manifold set for Sartoclear® Sartobind®, 1½" sanitary clamp	2
2ZGL--0005	Pilot filter holder for Sartoclear® Sartobind®	1
2ZGL--0006	Process filter holder for Sartoclear® Sartobind®	1
2ZGL--0007	Double process filter holder for Sartoclear® Sartobind®	1
2ZGL--0008	Drip pan for Pilot Filter holder	1
2ZGL--0015	Drip pan for Process and double Process Filter Holder	1

12 Dimensions and Connections

Membrane volume 8 mm bed height	 3 mL	 150 mL	 400 mL
Size	nano	5"	10"
Dimensions in mm	37×33 H×Ø	190×77 H×Ø	350×100 H×Ø
Connectors	Luer female	Sanitary ¾" 25 mm outer, 14 mm inner diameter"	Sanitary 1½" 50.5 mm outer, 36 mm inner diameter
Gaskets	n.a.	¾", inner diameter 16 mm	1½", inner diameter 35.8 mm

n.a.=not available



800 mL

20"

570×100
H×Ø

Sanitary 1/2"
50.5 mm outer,
36 mm inner
diameter

1/2",
inner diameter
35.8 mm



1.2 L

30"

810×100
H×Ø

Sanitary 1/2"
50.5 mm outer,
36 mm inner
diameter

1/2",
inner diameter
35.8 mm



5 L

Jumbo

850×302
H×Ø

Sanitary 1/2"
50.5 mm outer,
36 mm inner
diameter

1/2",
inner diameter
35.8 mm



1.6 L

Cassette

634×387×49
W×L×Ø

Via manifold:
Sanitary 1/2"
50.5 mm outer,
36 mm inner
diameter

For manifold:
1/2", inner diameter
35.8 mm

Sartorius Stedim Biotech GmbH
August-Spindler-Strasse 11
37079 Goettingen, Germany

Phone: +49 551 308 0
www.sartorius.com

First published:
March 15, 2018
Sartorius Stedim Biotech GmbH,
Goettingen, Germany

Printed in the EU on paper bleached
without chlorine.
DIR: 2624863-000-00

The information and figures
contained in these instructions
correspond to the version date
specified below.

Sartorius reserves the right to make
changes to the technology, features,
specifications and design of the
equipment without notice.

Masculine or feminine forms
are used to facilitate legibility in
these instructions and always
simultaneously denote the other
gender as well.

Copyright notice:

This instruction manual, including
all of its components, is protected
by copyright. Any use beyond the
limits of the copyright law is not
permitted without our approval.
This applies in particular to
reprinting, translation and editing
irrespective of the type of media
used.

© Sartorius Germany

Last updated:
08 | 2020