



BIOSTAT® D-DCU

Your "Fast Lane" to Production



Agenda

- Introduction
- System Overview
- Hybrid Solution

Drivers of Standardization for Stainless Steel Fermentation Systems



Key Drivers for Standardization

- Optimized and proven design
- Simplified and fast project execution
- Spare part availability
- Trained service technicians close to your operation
- Fast delivery
- Reduced costs
- Quickly up and running after commissioning
- Simplified process transfer from one site to the other

BIOSTAT® D-DCU Ideal Platform for :

- Process development
- Process optimization
- Up-scale and down-scale
- Production





Agenda

- Introduction
- **System Overview**
- Hybrid Solution

BIOSTAT® D-DCU

Your "Fast Lane" to Production



BIOSTAT® D-DCU

- Standardized, fully-featured SIP | CIP -System
- Microbial and cell culture applications
- Process development to production
- Single or Twin configuration
- Working volumes 10L, 20L, 30L, 50L, 100L, 200L
- Hybrid process solutions for upstream

SIP: Sterilization in Place
CIP: Clean in Place

BIOSTAT® D-DCU System Overview

Supply unit

- : Open frame design
- : Thermostat system
- : Gas inlet
- : Exhaust

Culture vessel

- : Flat top plate
- : Bottom agitation system
- : Working volume 10 - 200L
- : H : D ratio (total): 2 : 1 or 3 : 1
- : Various top plate and side ports
- : Sanitary TC sampling port

Control Tower

- : Single or Twin configuration
- : DCU control System
- : Touch panel
- : Integrated gassing system
- : Integrated pumps



BIOSTAT® D-DCU Control Tower



Control Tower –Single

Control Tower –Twin

Control Tower

- Single or Twin Configuration
- 19" Color display with touch screen
- Industrial PC
- Integrated amplifier rack
- Integrated Gassing Module
 - : Airflow (Microbial applications)
 - : O₂-Enrichment (Microbial applications)
 - : Gas Flow Ratio Control (Microbial applications)
 - : Advanced Additive Flow (Cell culture applications)
- Up to 6 integrated pumps per vessel
- Agitation motor controller

For Twin Configuration please note:

Both vessels may need to be sterilized at the same time since different compressed air settings are may be required for fermentation and sterilization.

BIOSTAT® D-DCU Gassing Strategy

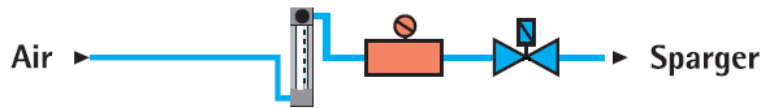

"Airflow"

- Rotameter for Sparger flow
- Intermitted sparging of air controlled by DOT controller
- Option: DOT control via mass flow controller

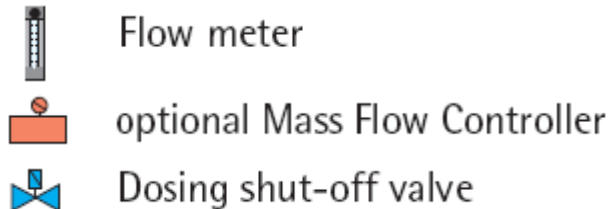

BIOSTAT® D-DCU Gassing Strategy

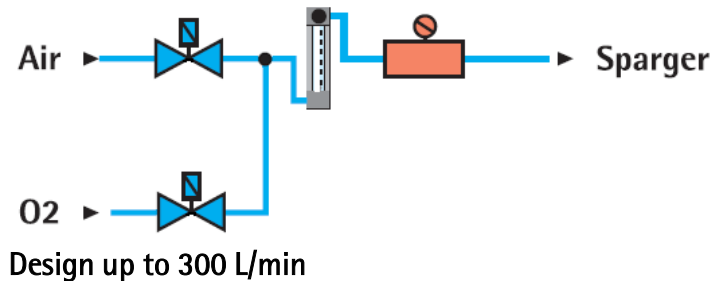
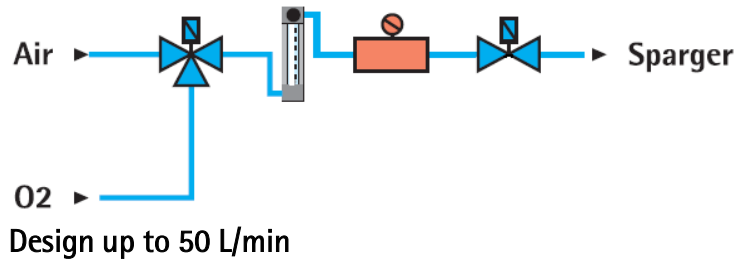

Flow meter



3-way dosing valve



optional Mass Flow Controller



Dosing shut-off valve

"O2-Enrichment"

- Gassing system with O2 enrichment capability via solenoid valve
- Rotameter for Total Sparger flow
- Intermittent O2 enrichment controlled via DOT controller
- **Option:** Mass Flow Controller for Total Sparger Flow

BIOSTAT® D-DCU Gassing Strategy

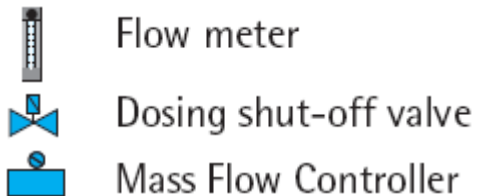
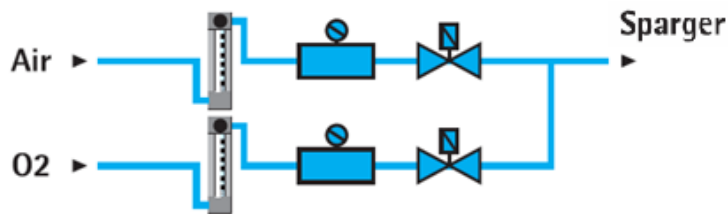



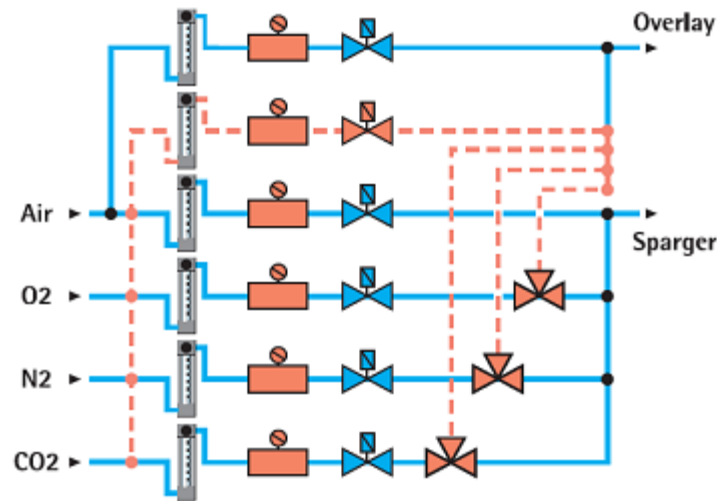

“Gas Flow Ratio Control”

- Air flow gassing system with O₂ supplementation capability via mass flow controller for Air and O₂
- Continuous gas flow control of Air and Oxygen via DOT controller
- Rotameter for Total Sparger flow
- O₂ Supplementation automatically controlled via pO₂ controller

BIOSTAT® D-DCU Gassing Strategy



-  Flow meter
-  Dosing shut-off valve
-  optional dosing shut-off valve
-  optional Mass Flow Controller
-  optional Gas switch

"Advanced Additive Flow"

- Mixing of up to four gases
Air, N₂, O₂ and CO₂
- Sparger and Overlay gas outlets
- Air, O₂, N₂, CO₂ routed to Sparger,
Air routed to Overlay
- Intermittent or Continuous gas flow control of
Air, O₂ and N₂ via DOT controller
- Intermittent or Continuous gas flow control of
CO₂ via pH controller
- Each flow path with flow meter
- Each flow path with dosing/ shut off valve
- **Option:** 6th flow path
- **Option:** Gas switch Sparger or Overlay
- **Option:** Up to 6 mass flow controller

BIOSTAT® D-DCU Pumps



Control Tower –Single



Control Tower –Twin

Integrated Pumps

- Up to 6 integrated peristaltic pumps per vessel
 - 1 & 2 fixed speed, on/ off controlled
 - 3 & 4 fixed speed, on/ off controlled
or speed controlled
 - 5 & 6 speed controlled
- Watson Marlow pump heads
 - fixed speed WM 114, 5 rpm
 - fixed speed WM 114, 44 rpm
 - speed controlled WM 114, 0.1-200 rpm
 - speed controlled WM 314, 0.1-200 rpm
- 2 x Connector for external speed controlled pumps per vessel

BIOSTAT® D-DCU Human Machine Interface (HMI)



Human Machine Interface (HMI)

- Intuitive to use
- Touch panel
- 19" TFT display
- Swivel-mounted

BIOSTAT® D-DCU Operation-Main

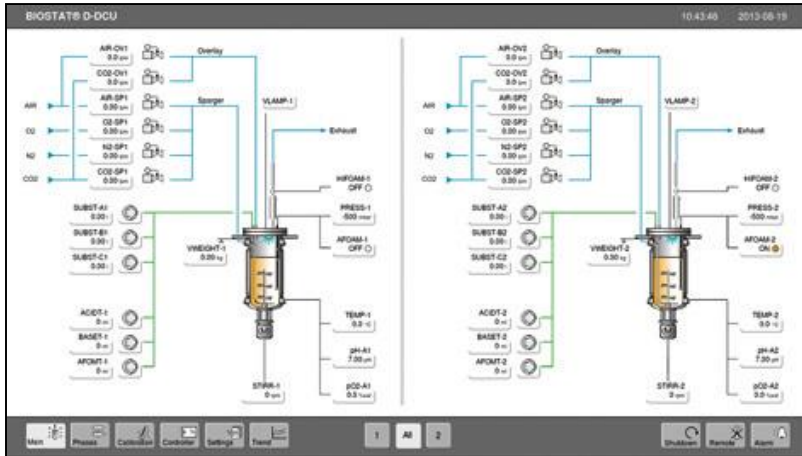

Control Tower –Operation Main

- Vessel process value overview at a glance for Twin systems
- Unit vessel detail process value overview
- Controller status indication

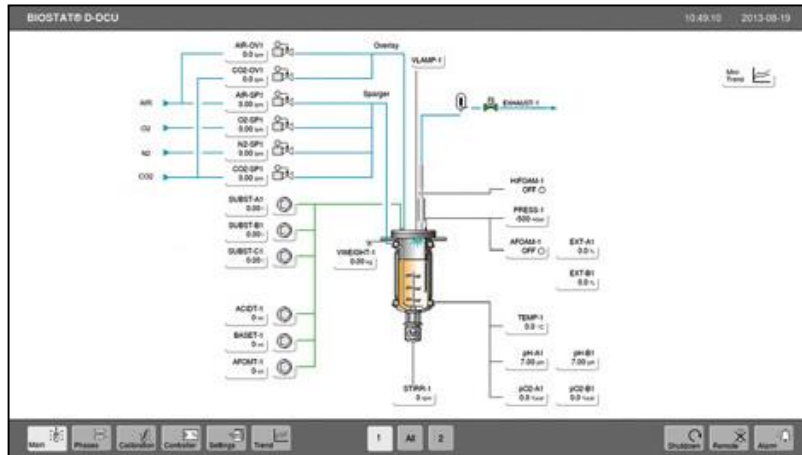
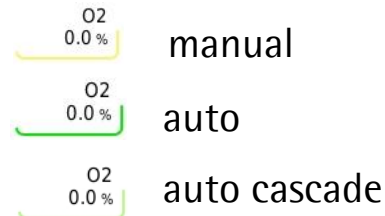

BIOSTAT® D-DCU Operation-Trend

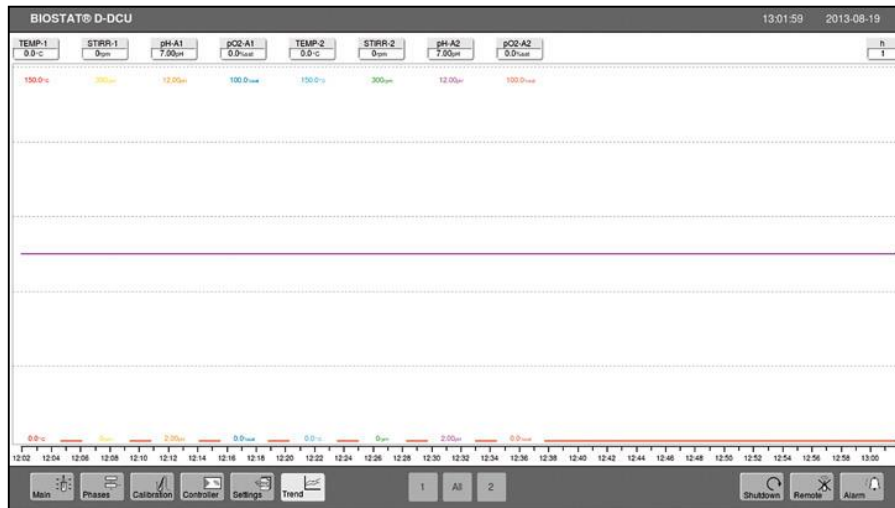

Control Tower -Operation Trend Display

- Up to 8 process variables
- Display time selectable
 - : 1 hour
 - : 12 hours
 - : 72 hours
- Selectable ranges
 - : for each process value
 - : % value of measurement range
- Temporary storage only

BIOSTAT® D-DCU –Control Tower Operation-Calibration

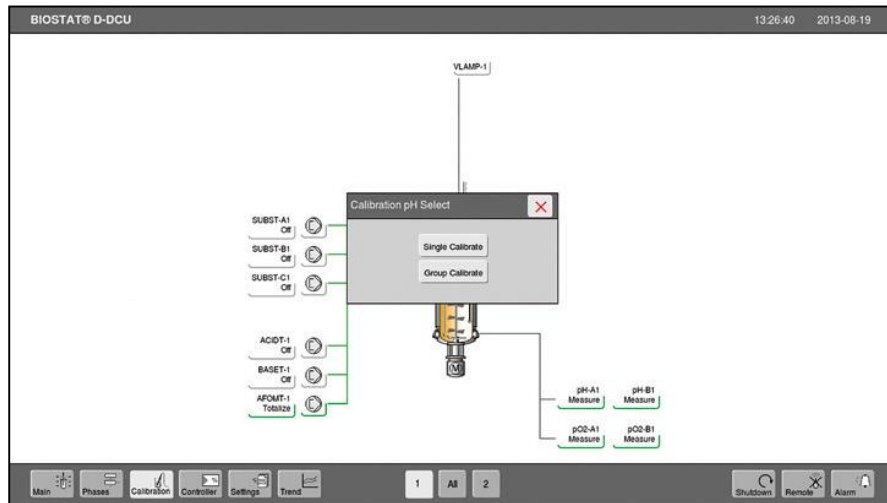

Control Tower -Operation Calibration

- Single or Group calibration
- User guided calibration routines
- For pH, DOT, turbidity, redox probes
- For pumps (flow totalizer)
- For gas solenoids (gas totalizer)

BIOSTAT® D-DCU Operation-Controller

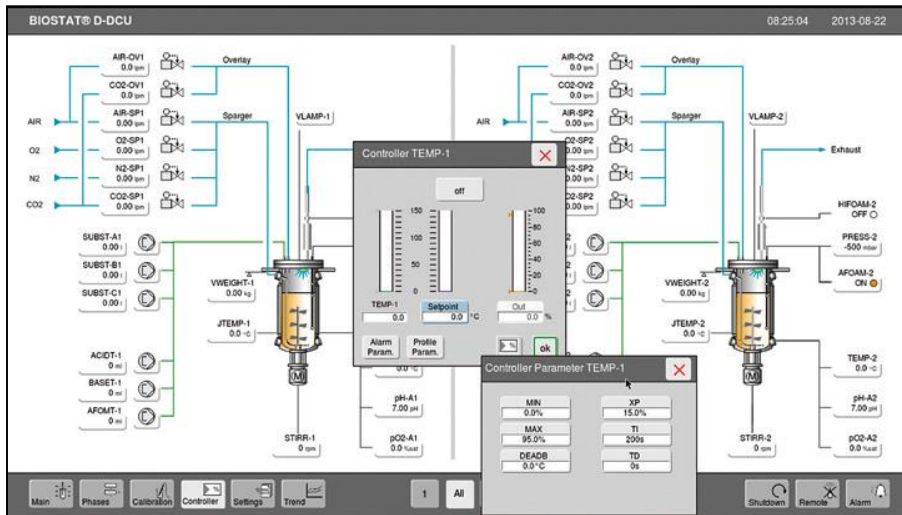

Control Tower Operation – Controller

- Operations
 - : Mode selection
 - : Servo controller selection
 - : Set point changes
 - : Parameter changes
 - * min./ max. out put
 - * PID parameter
 - * Dead band
 - : Alarm setting

BIOSTAT® D-DCU

Operation Advanced DOT Controller

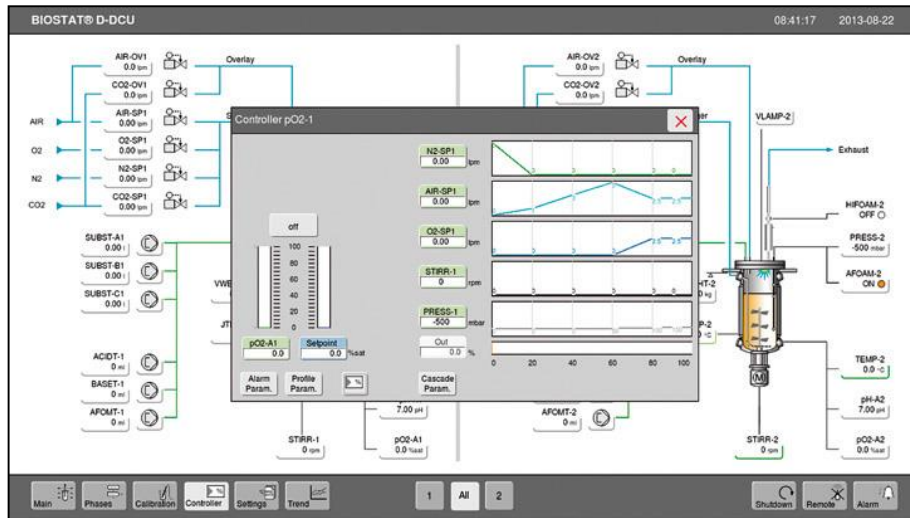

Advanced pO2 Controller

- Up to 4 servo controllers
- Free user configurable polyline for parallel or sequential control
- Starting points are depending on DOT controller output
- Selectable starting points

BIOSTAT® D-DCU Operation-Phases

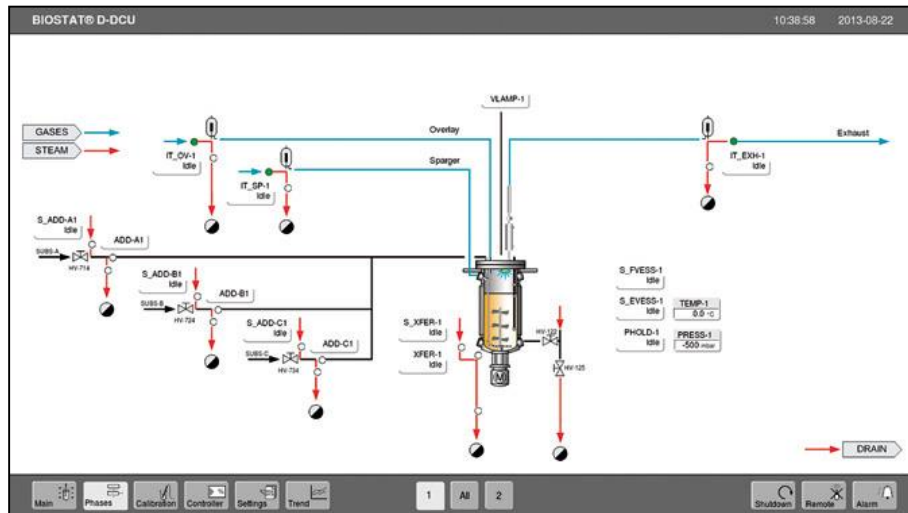

Control Tower -Operation Phases

Sequence control with interlocks for

- Sterilization
 - Full vessel, incl. gas inlet and exhaust line
 - Empty vessel incl. gas inlet and exhaust line
 - 4-Valve addition array
 - Separate Exhaust filter line
 - Sampling valve
 - Darin valve
 - Transfer group
- WIT test with external filter check system
- CIP sequence
- Valve switch

BIOSTAT® D-DCU

Measurement and Control Capabilities

	Measurement	Control	Comments
Agitation speed	X	X	Servo drive
Temperature	X	X	Controlled via closed loop thermostat system
pH_1 & pH_2	X	X	Controlled via CO2 (Solenoid) or MFC / Acid pump + Base pump (analogue or digital)
pO2_1 & pO2_2 (Clark or Optical)	X	X	Controlled via agitation speed; O2/ N2 supplementation (solenoid or MFC); Substrate; Pressure
Foam	X	X	Conductivity probe
Level	X	X	Conductivity probe
Redox	X	-	
Vessel pressure	X	X	
Vessel weight	X	X	
Turbidity (Cell density)	X	X	Fundalux II
Substrate A & B & C & D	(X) via GFC	X	Control of internal unused or additional optional peristaltic pump (internal or external)
External signals	X		For connection of external amplifier
MFC 1....6 (Air, N2; O2; CO2)	X	X	
Balances 1....4	X	0	For Gravimetric Flow Control or addition vessel weight measurement .
Other measurements and control can be implemented according to customer specification e.g. CO2 in liquid, exhaust (O2 & CO2), etc.			

BIOSTAT® D-DCU Supply Unit

Supply Unit

Open frame design with...

- Gas inlet and Exhaust line
- Thermostat system
 - Closed-loop pressurized water system with circulation pump and heat exchanger for cooling
 - Heating
 - : 10-30L: Alternatively via stainless steel heat exchanger (copper soldered) or electrical heating for fermentation and sterilization. Please note: Empty vessel sterilization requires clean steam supply
 - : Option: Stainless steel heat exchanger (stainless steel welded)
 - : 50-200L: Auxiliary electrical heater available (for process temp control only)
- Temperature control range
 - 8 °C above cooling water up to 90 °C
- Sterilization temperature
 - up to 130 °C

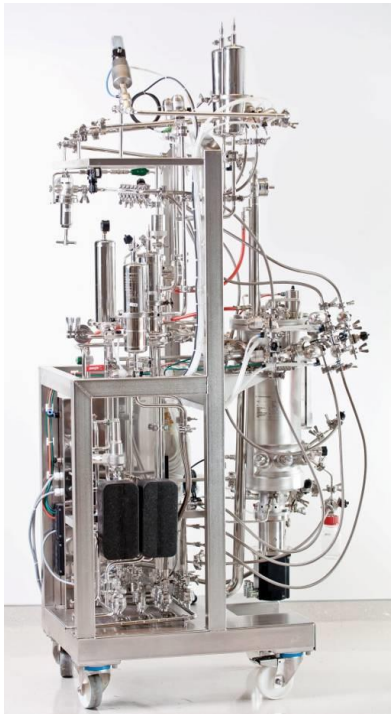

Supply unit 10-30L

BIOSTAT® D-DCU

Supply Unit Components: 10-30L

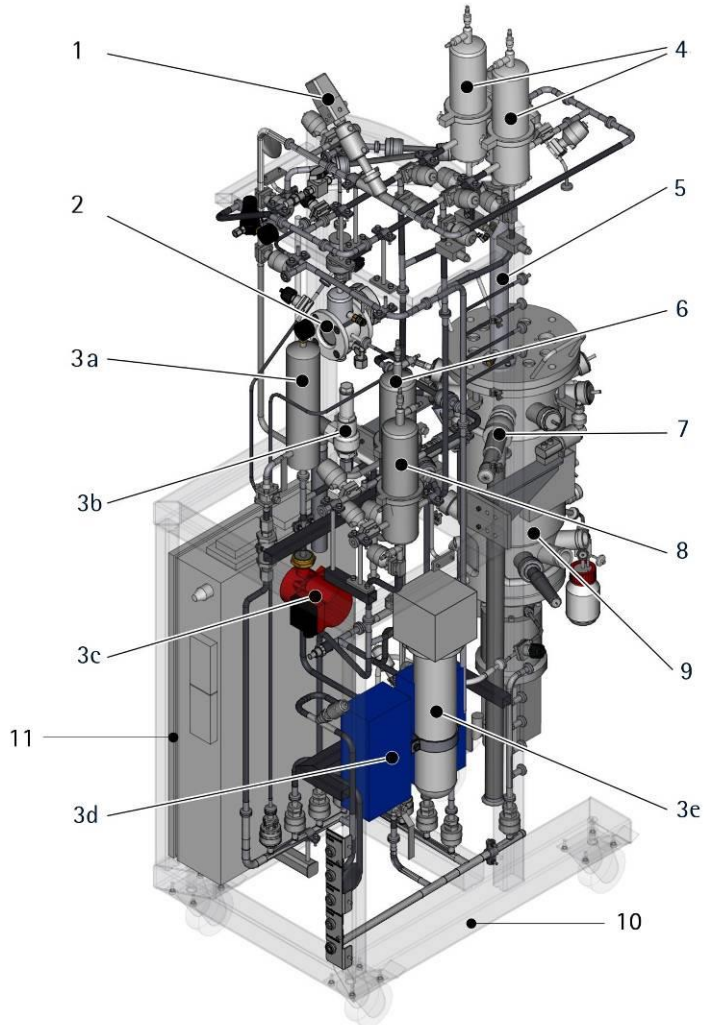

1	Pressure control valve
2	Sight glass buffer system DMS
3	Temperature control system
3a	Pressure compensation vessel
3b	Safety valve
3c	Circulation pump
3d	Heat exchanger
3e	Variant: Electrical heating
4	Variant: Dual exhaust filter line
5	Exhaust cooler
6	Gas inlet filter "Sparger"
7	Safety valve / Bursting disc w/ flow tube
8	Gas inlet filter "Overlay"
9	Culture vessel
10	Piping frame on casters
11	PV-Box w/ electrical and pneumatic components

BIOSTAT® D-DCU

Supply Unit Components: 50-200L

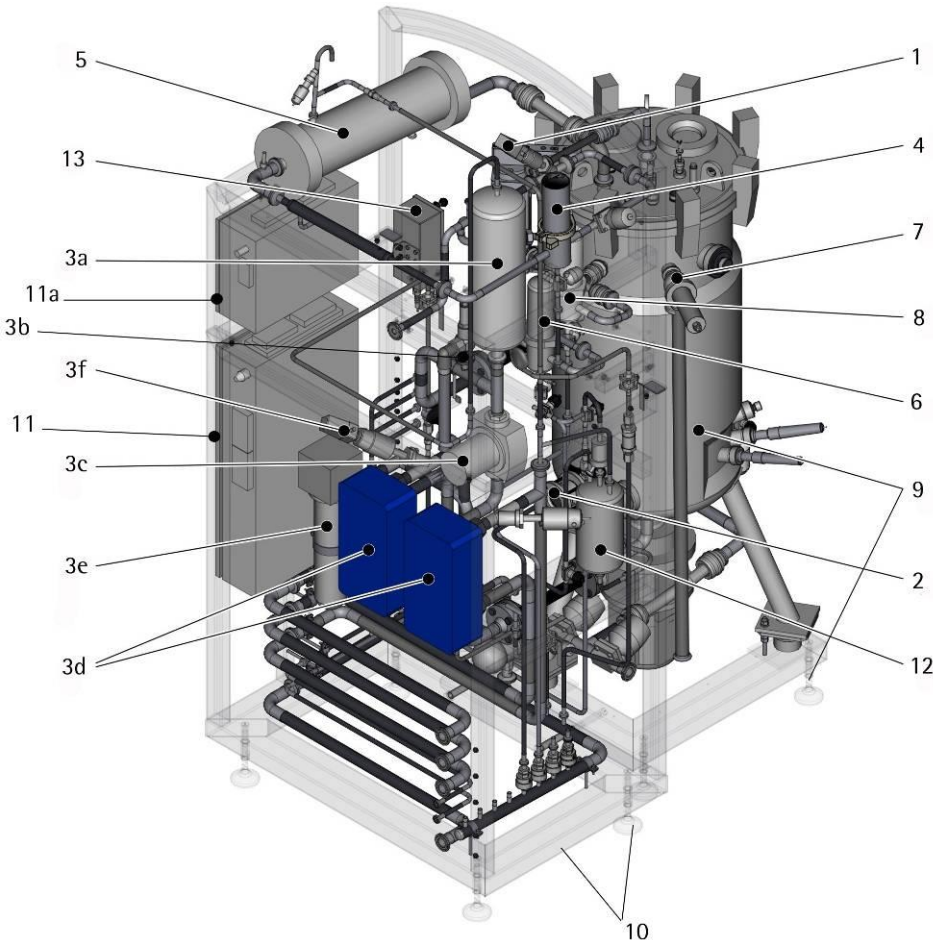

1	Pressure control valve
2	Sight glass buffer system DMS
3	Temperature control system
3a	Pressure compensation vessel
3b	Safety valve
3c	Circulation pump
3d	Heat exchanger
3e	Auxiliary electrical heater
3f	Continues controlled steam valve
4	Exhaust filter
5	Exhaust cooler
6	Gas inlet filter "Sparger"
7	Safety valve / Bursting disc w/ flow tube
8	Gas inlet filter "Overlay"
9	Culture vessel w/skit and leveling feet's
10	Piping skid w/ feet's
11	PV-Box w/ electrical and pneumatic components
11a	PV-Box extension
12	Buffer fluid vessel for DMS
13	Control box lid lifting device

BIOSTAT® D-DCU Gas Inlet



Sparger aeration

- Stainless steel filter housing
- Bypass line if no Overlay line is installed
- **Option:** WIT ready filter housing

Overlay aeration (Cell culture)

- Stainless steel filter housing
- **Option:** WIT ready filter housing

BIOSTAT® D-DCU Exhaust



Dual w/ WIT (10-30L)



Basic (10-30L)



Dual w/ WIT (50 - 200L)

Exhaust filter, basic (10-30L only)

- Stainless steel filter housing directly mounted on Exhaust cooler
- High foam sensor included

Exhaust filter line (10-200L)

Single filter line

or

Dual parallel filter line for in process sterilization

Stainless steel filter housing

High foam sensor included

Option: Exhaust heater

Option: WIT ready filter housing

BIOSTAT® D-DCU Supply Unit Exhaust Cooler / Pressure Control Valve



Exhaust cooler (50 – 200L)



Pressure control valve

Exhaust Cooler (10-30L)

- Mounted on culture vessel lid
- Shell and tube heat exchanger

Exhaust Cooler (50-200L)

- Mounted in piping skid
- Shell and tube heat exchanger

Pressure control valve

- Mounted in piping skid

BIOSTAT® D-DCU Culture Vessel



Culture vessel

- Vessel with bottom agitation
- Working volume 10, 20, 30, 50, 100, 200L
- Aspect ratio H : D (total): 2:1 or 3:1
- Jacketed stainless steel vessel with torospherical bottom
- Longitudinal viewing window
- Vessel fabrication: PED or ASME or China licence
- Material
 - : Product contact: stainless steel AISI 316L, EPDM, borosilicate glass others: AISI 304
 - : Surface: internal: Ra [3:1 | 2:1] \leq 0.8 | 0.4 μ m, electropolished

BIOSTAT® D-DCU

Volume Overview

Vessel description	Working Volume [L]	Total Volume [L]
10-2 10-3	4,5 – 10 3,5 – 10	14 15
20-2 20-3	5.5 – 20 3.5 – 20	29 31
30-2 30-3	6.5 – 30 5.5 – 30	42 41
50-2 50-3	13 – 50 13 – 50	74 77
100-2 100-3	24 – 100 24 – 100	152 152
200-2 200-3	47 – 200 41 – 200	313 323

BIOSTAT® D-DCU

Culture vessel port overview

Description	Vessel	10 L	20 L	30L	50 L	100 L	200 L
Lid		1 x sight glass for illumination 1 x port for Exhaust 9 x 19 mm port Lifting handles			1 x sight glass for illumination 1 x spare port DN 50 1 x port for CIP - connection (2x 200L) 1 x port for Exhaust 8 x 19 mm port 3 x lifting eyes		
Upper side ports		4 x 25 mm port 1 x Sparger aeration 1 x Overlay aeration / Bypass Sparger 1 x port for rupture disc / safety valve 1 x rectangular sight glass			3 x 25 mm port 1 x Sparger aeration 1 x Overlay aeration / Bypass sparger 1 x port for rupture disc / safety valve 1 x DN50 1 x rectangular sight glass		
Lower side ports		5 x 25 mm port 1 x sanitary TC 50.5 port 1 x port for temperature sensor			5 x 25 mm port 1 x sanitary TC 50.5 port 1 x port for temperature sensor		
Bottom		1 x flange for agitator 1 x Harvest / Drain valve			1 x flange for agitator 1 x Harvest / Drain valve		

BIOSTAT® D-DCU

Scalability via geometrical similarity

Scale	10-2	20-2	30-2	50-2	100-2	200-2	10-3	20-3	30-3	50-3	100-3	200-3
Total volume [L]	14	29	42	74	152	313	15	31	41	77	152	323
Working volume [L]	10	20	30	50	100	200	10	20	30	50	100	200
Min. working volume [L]	3,5	5,5	6,4	13	24	47	2,5	3,5	5,4	13	24	41
H:D ratio [Total Volume]	2.0	2.0	2.2	2.4	2.2	1.9	2.9	3.0	2.9	3.1	3.2	3.2
H:D ratio [Working Volume]	1.3	1.4	1.6	1.6	1.5	1.3	1.9	1.9	2.1	2.1	2.1	2.1
Impeller to vessel diameter ratio	6-blade disc Impeller						6-blade disc Impeller					
	0.40	0.40	0.39	0,39	0.40	0.40	0.40	0.40	0.40	0.40	0.41	0.40
Max. impeller tip seed	6.7	6.6	6.6	6.4	6.6	7.0	5.9	6.0	6.0	5.9	5.9	6.0
Impeller to vessel diameter ratio	3-blade segment impeller											
	0.40	0.40	0.39	0,39	0.40	0.40						
Max. impeller tip seed	1.9	2.1	2.0	2.0	2.1	2.0						

BIOSTAT® D-DCU Lid Lifting Device



Lid lifting device 200L

Lid lifting device

- Available for vessel sizes from 30 – 200L
- Pneumatic operated
- Swivel and lockable

BIOSTAT® D-DCU Agitation Shafts

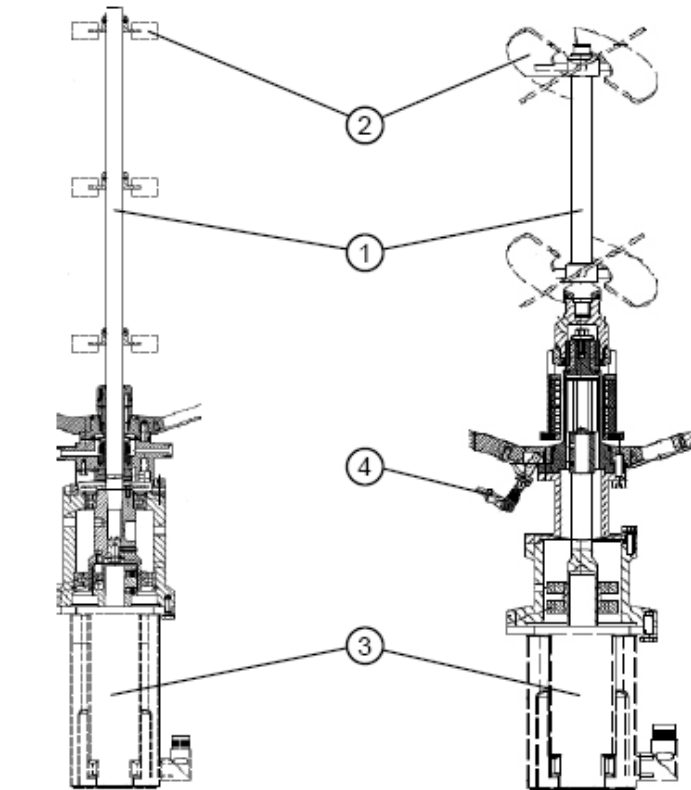

Agitator w/ DMS

① Stirrer shaft

Magnetic drive

② Impeller

③ Motor

④ Speed sensor

Agitation shaft sealing

Double mechanical seal w/ buffer fluid system

- For microbial and cell culture application
- Lubricated by pressurized condensate
 - Compressed Air pressurization
 - Option:** Low level alarm monitoring
 - Steam pressurization

- Sealing material: SIC/carbon graphite

- Condensate vessel with viewing window

Magnetic drive

- For cell culture application only
- Shaft speed monitoring

BIOSTAT® D-DCU Agitation Motor

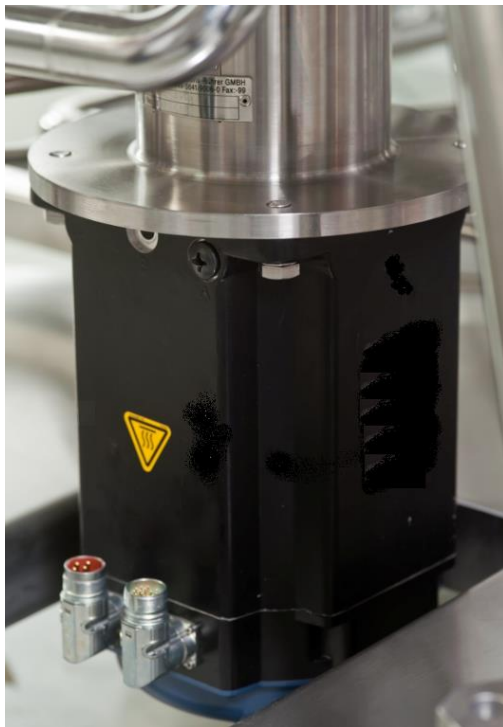

Agitation motor

- Bottom agitation system
- Brushless DC Servomotor
- Gear and maintenance free
- Easy to clean due to smooth surface

BIOSTAT® D-DCU

Impeller for Microbial Application

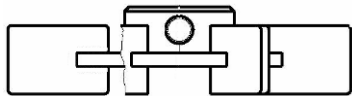
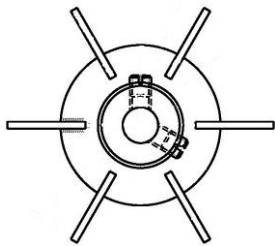
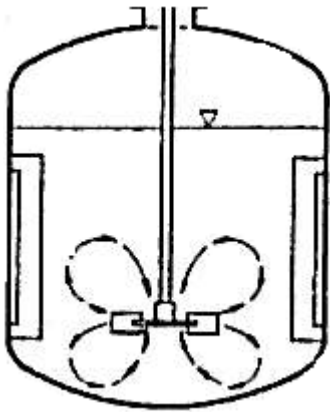

6-blade disk impeller

The 6-blade disk impeller produces a flow which moves radially away from the shaft and has a high energy dissipation density. This impeller breaks up air bubbles effectively and thereby improves oxygen transport in the liquid phase. At the same time, high local shear forces are also generated which can have a negative influence on the growth of shear-stress-sensitive organisms (cell cultures, filament-producing fungi).

Design:

Impeller diameter = $0.4 \times$ inner vessel diameter

BIOSTAT® D-DCU

Impeller for Cell Culture Application

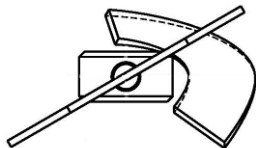
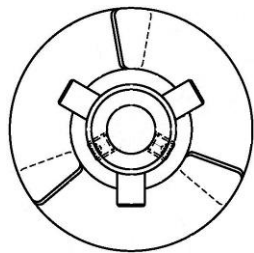
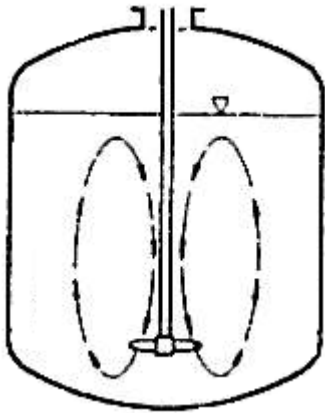

3-blade segment impeller

3-blade segment impellers for cell culture applications, especially for shear sensitive cells and microcarrier cultures.

The impeller creates an axial downward flow (upward flow version available as option) and thereby achieves homogenous and thorough mixing of the culture medium while minimizing shearing forces.

Design:

Impeller diameter = $0.5 \times$ inner vessel diameter

BIOSTAT® D-DCU Aeration Devices

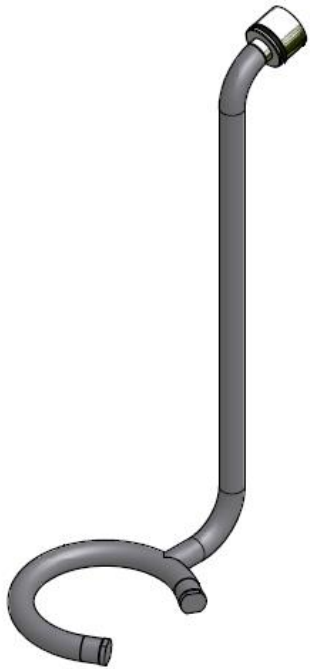

Ring sparger

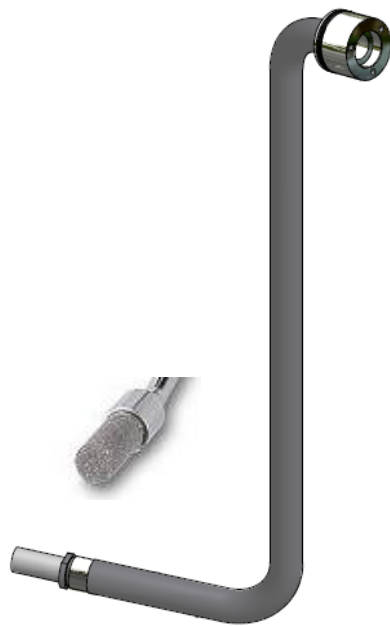

μ-sparger

Microbial and Cell Culture application

- Ring sparger for 25 mm upper side port
- Holes from bottom

Cell culture application

- Micro sparger for 25 mm upper side port
- Sintered stainless steel frit 20 μm

BIOSTAT® D-DCU

Addition Devices: Needle Kits

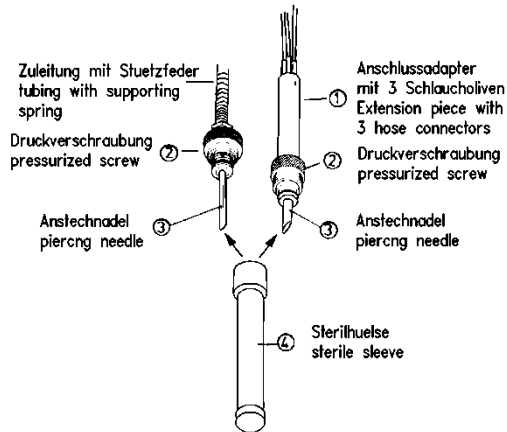

Needle assembly for 19 mm port

Product description

- For installation 19 mm top plate port
- Available as
 - : 1-Channel assembly
 - : 3-Channel assembly

Operation:

1. Sterilization in an autoclave together with the addition bottles
2. Sterilization of the culture vessel with septum/ blind plug assembly
3. Remove septum blind plug and the sterile sleeve of the needle and pierce the septum with the needle

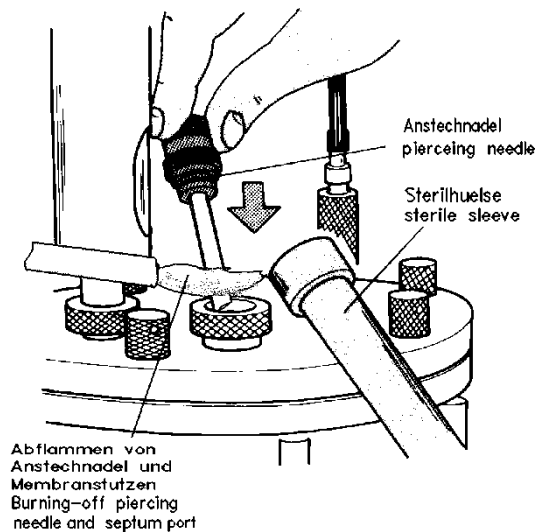

BIOSTAT® D-DCU

Addition Devices: SACOVA



Sacova valve closed



Sacova valve open

Safety Containment Valve (Sacova)

Product description

- Sterile valve for a 19 mm top plate port
- 1-Channel or 3-Channel assembly available
- For tubing 3,2 x 1,6 mm
- High containment class

Operation:

1. Sterilization in an autoclave together with the addition bottle or connected C-flex tubing using a BioWelder for sterile connection
2. After autoclaving installation in the culture vessel and sterilization together with the culture vessel

BIOSTAT® D-DCU

Addition Devices: 4-Valve Addition Array

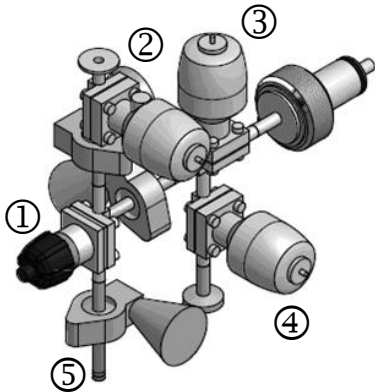

- ① Manual addition valve
- ② Steam valve
- ③ Bioreactor valve
- ④ Condensate valve
- ⑤ Hose barb for feed connection



4-Valve Addition Array, auto

Product description

- Automatic resterilizable valve array for 25 mm port
- For multiple sterile connections during the process
- Perfect fit for connection of bags using BioWelder
- High containment class

Operation:

1. Automatic sterilization independently of culture vessel
2. Manual addition valve to be autoclaved with addition bottle/ bag or TPE tubing
3. After autoclaving connection of addition valve and sterilization by steaming of connection lines

BIOSTAT® D-DCU

Addition Devices: 4 Valve Addition Array, man

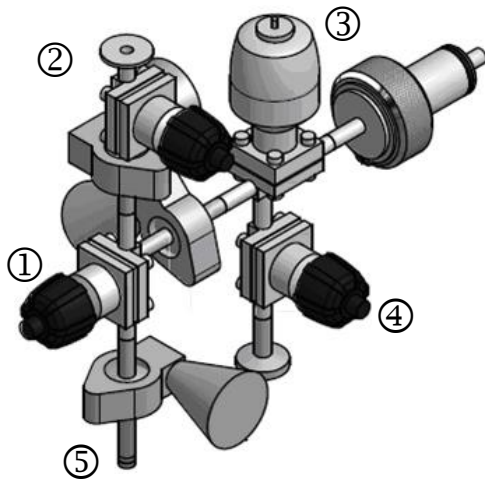

- ① Manual addition valve
- ② Steam valve
- ③ Bioreactor valve
- ④ Condensate valve
- ⑤ Hose barb for feed connection

4-Valve Addition Array, man

Product description

- Resterilizable valve array for 25 mm port
- Automatic bioreactor, manual valves for steam, condensate and addition
- For multiple sterile connections during the process
- Perfect fit for connection of bags using BioWelder
- High containment class

Operation:

1. Manual sterilization separate to culture vessel
2. Manual addition valve to be autoclaved with addition bottle/ bag or TPE tubing
3. After autoclaving connection of addition valve and sterilization by steaming of connection lines

BIOSTAT® D-DCU Sampling



Resterilizable Sampling Valve, Keofit

Product description

- Resterilizable Keofit sampling valve for TC 50.5 sanitary port
- For multiple samplings during the process
- Manual steam valve
- Incl. Sterile sleeve
- **Optional:** Automatic sterilization via automatic steam valve

BIOSTAT® D-DCU Containment Sampling



Resterilizable Containment Sampling System

Product description

- Resterilizable Keofit sampling valve for TC 50.5 sanitary port
- For multiple sterile samplings during the process
- Manual steam and condensate valves
- Containment sampling bottle
- **Optional:** Automatic sterilization via automatic steam and condensate valves

BIOSTAT® D-DCU Single-use Sampling

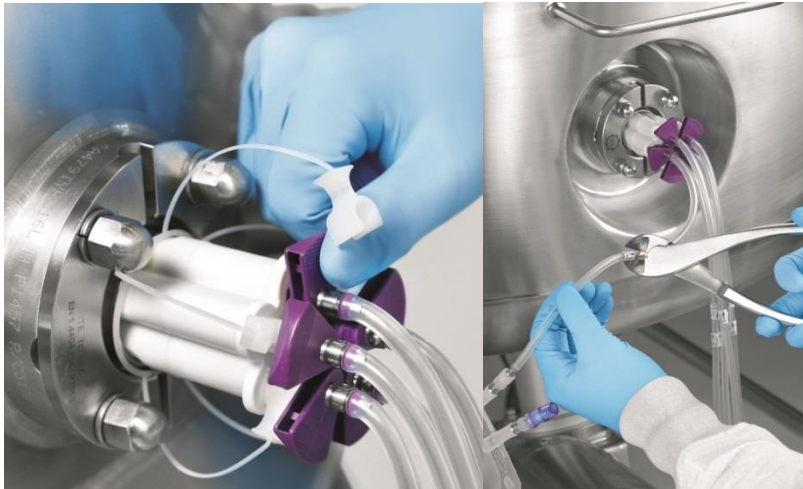

TAKEONE® Single-use sampling

- Aseptic sampling system
- Ready to use
- NO cleaning, preparation and sterilization
- QUICKSEAL®: aseptic tube sealing system
- Sampling bag sealed & disconnected in seconds

BIOSTAT® D-DCU Drain Valve

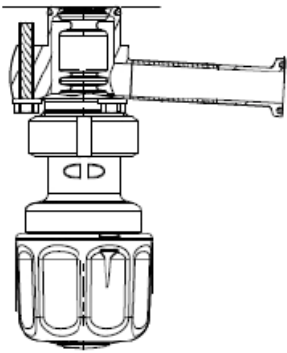

Drain valve (100-200L)

Drain valve

Product description

- Radial sealed with TC connection
- Manual or automatic operated
- Sterile sleeve or Condensate line w/ steam trap
- **Optional:** Automatic sterilization via automatic steam and condensate valves or transfer group

BIOSTAT® D-DCU

Temperature Measurement of Condensate Lines

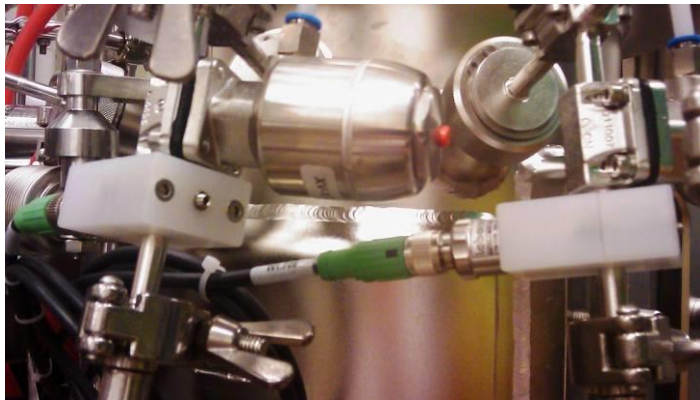

Contact temperature sensor at addition valve array

Temperature measurement of condensate lines

- For all relevant condensate lines in sterile area
- Contact temperature sensors
- Monitoring via Control Tower

BIOSTAT® D-DCU Transfer Valve Group



Transfer valve group (10-30L)

Transfer valve group (10-30L)

- Automatic valves for steam and Condensate lines
- Manual transfer valve

Transfer valve group (50-200L)

- Automatic valves for steam and Condensate lines
- Automatic transfer and drain valve

BIOSTAT® D-DCU Cleaning In Place (CIP)



Spray ball piping (200L)

Cleaning In Place

For the use of an external CIP system, culture vessel is used as a batching tank

- Available for vessel sizes 10 – 200L
- SIP / CIP header
- Automatic CIP sequence for:
 - : Culture vessel
 - : Aeration line
 - : Exhaust line
 - : 4-valve addition array, auto
 - : Transfer group
- Draining of all CIP lines with compressed air
- Option: Electronic discrete handshake signals (potential free signals)
 - 1) "DCU message": CIP request
 - 2) "CIP message": CIP confirm
 - 3) "CIP message": CIP run
 - 4) "DCU message": CIP cycle active

BIOSTAT® D-DCU mobile CIP Unit

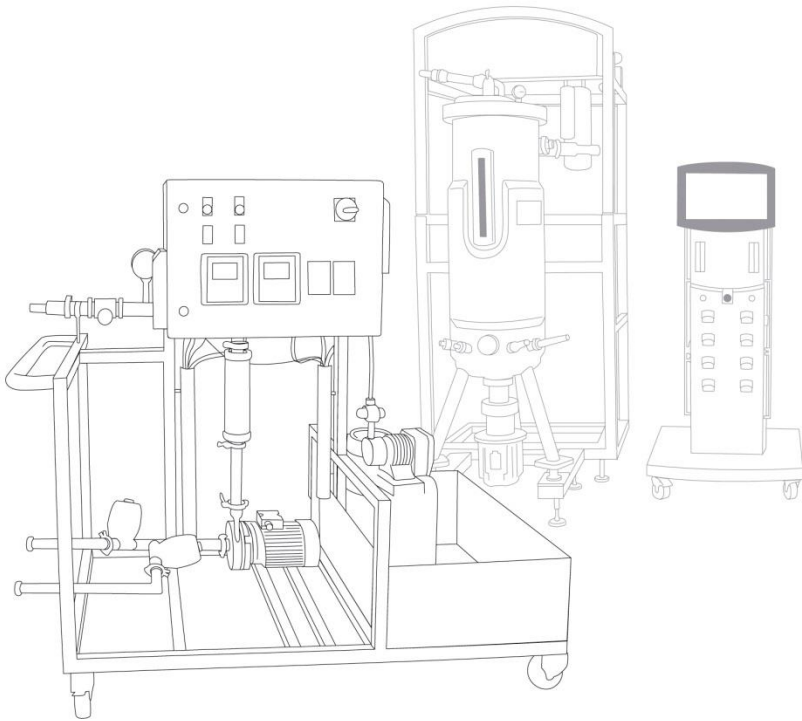

mobile CIP Unit

- One system for all vessel sizes (10L – 200L)
- High & low conductivity measurement
- Pump dry run protection
- Up two integrated dosing stations
- D-DCU communication interface for automated CIP sequence control

BIOSTAT® D-DCU Supporting Documentation

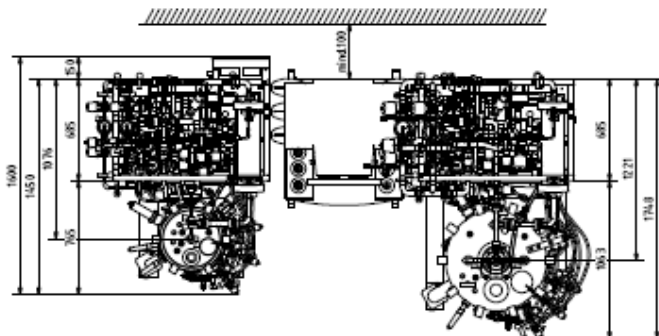
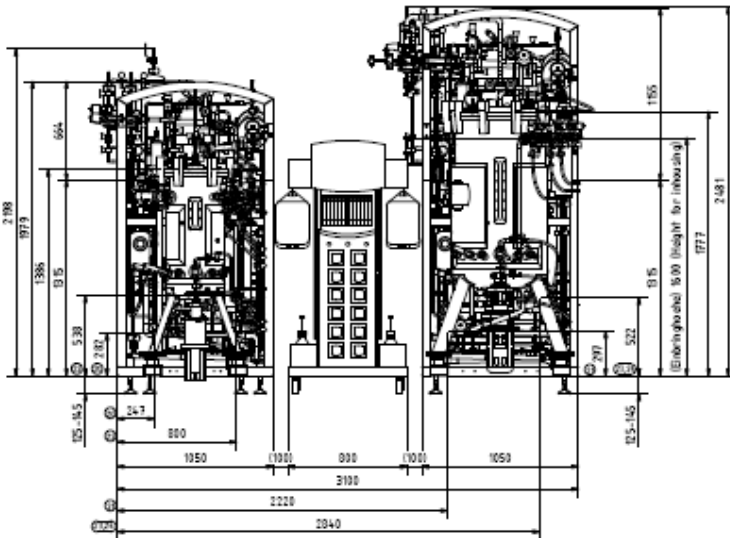

Supporting Documentation

Pre-order:

- Data sheet
- Arrangement plan
- Reference P&ID

Post-order:

- Reference 3D model for room planning
- Operating manual
- Consumable list
- Qualification package
 - As build P&ID
 - Material certificates
 - Functional specification
 - IQ/OQ protocols

Agenda

- Introduction
- System Overview
- **Hybrid solution**



Hybrid Solutions

Flexboy® or Flexel® bags can be connected to the BIOSTAT® D-DCU for corrective agent and feed addition to reduce cleaning effort. Together with our media preparation system FlexAct® MP and our cell harvest FlexAct® CH, a completely hybrid upstream process solution can be installed at unprecedented low investment cost and a short timeline.



FlexAct® MP (Media Preparation)



FlexAct® CH (Cell Harvest)

Drivers for Hybrid Solutions

- Reduced cleaning validation
- Pre-sterilized and pre-assembled storage vessels
- Simplified liquid handling and media preparation
- Convenient liquid transportation of feeds, intermediates etc.
- Lower capital investments
- Accelerated commissioning and qualification
- Cost savings

Common Stainless Steel Bioreactor Design

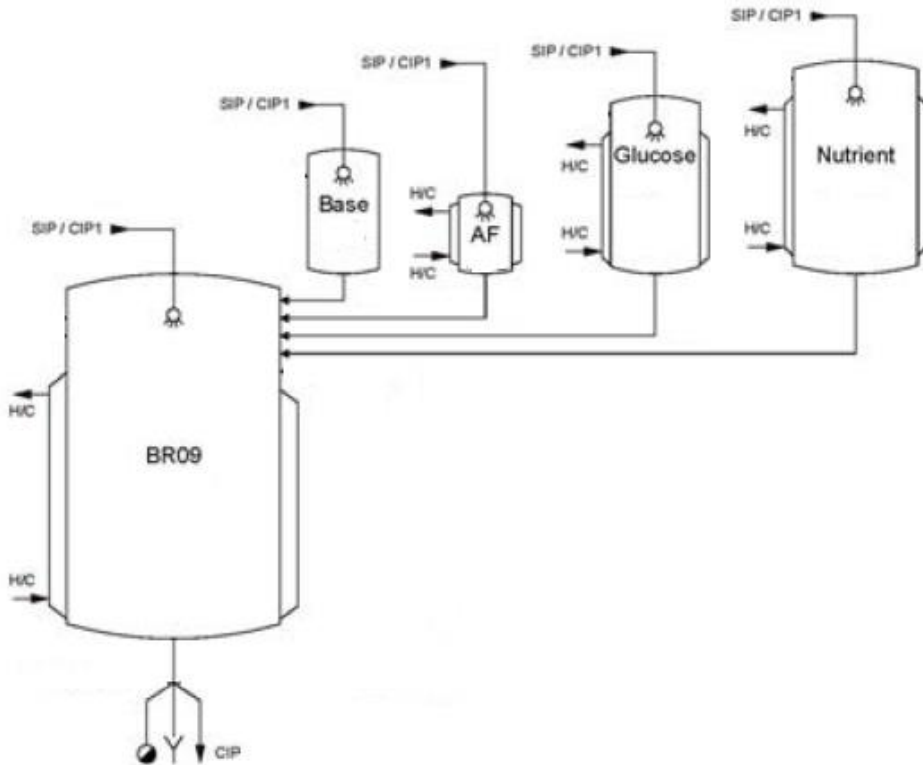

Common stainless steel bioreactor design

- Stainless steel storage vessels for corrective agents and feeds
- SIP / CIP requirements for all vessels
- High Steam / WFI requirements
- High capital investment

Example of a Hybrid Solution

Stainless Steel Bioreactor with Single-Use Bags

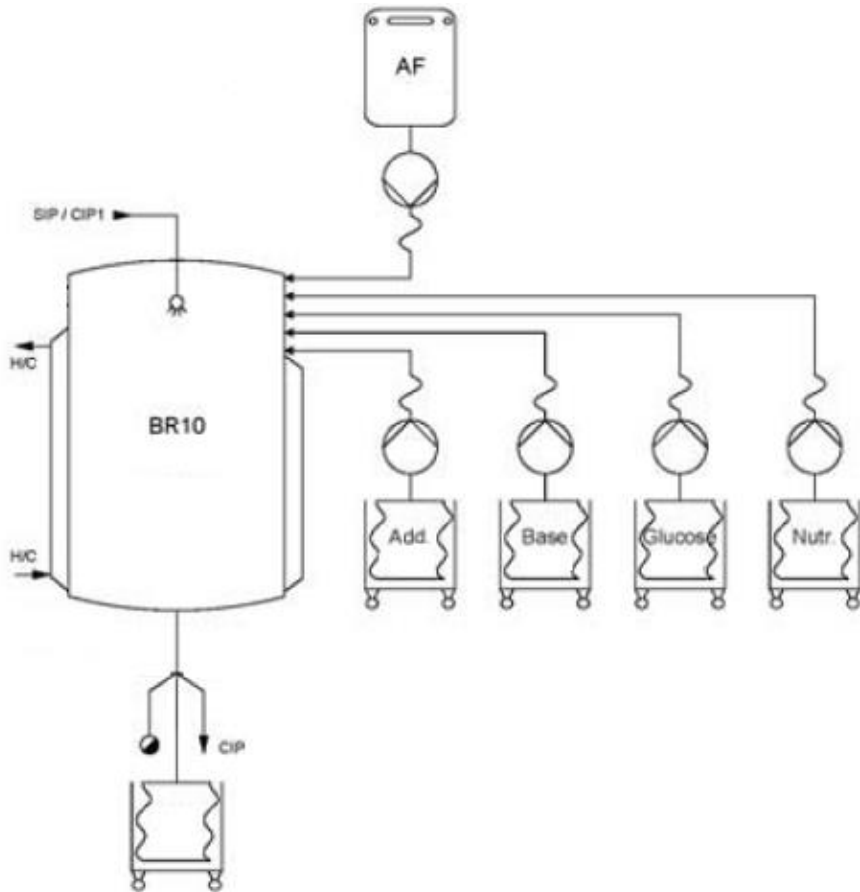

Advantages

- Single-use bags for media storage and harvest
- SIP / CIP requirement for bioreactor only
- Low Steam / WFI requirements
- Fully flexible
- Reduced cleaning validation
- Lower capital investment

Example of a Hybrid Solution

How to Connect Single-Use Bags?

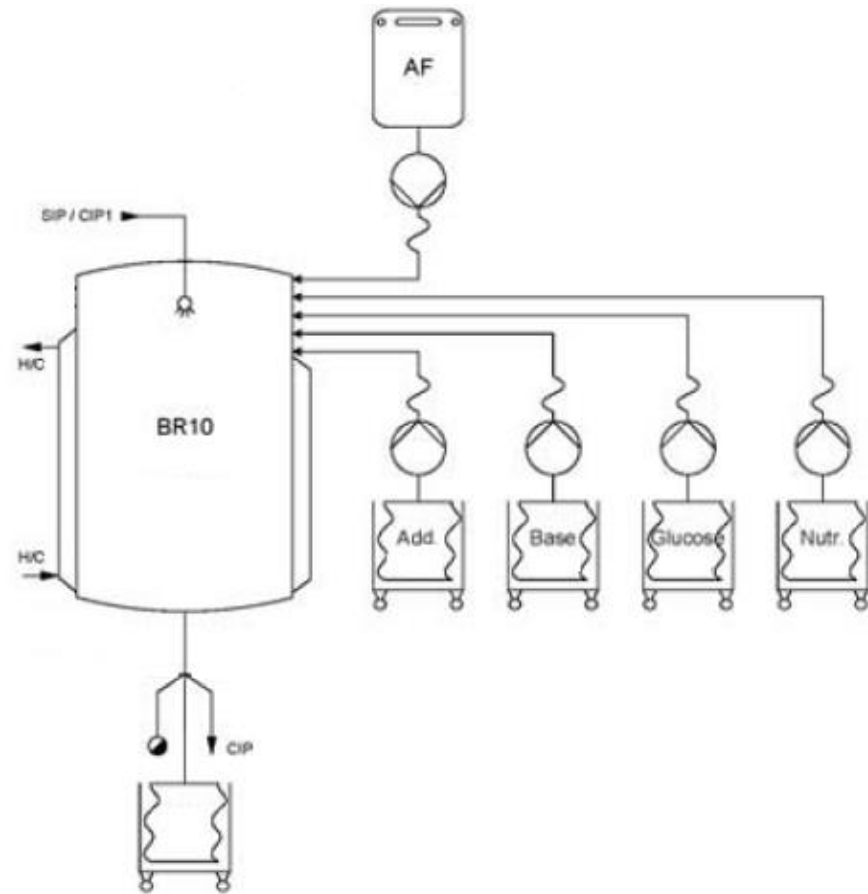

Tube welding, the easiest way to connect

Operation

- Autoclave re-usable valve with TPE tubing
- SIP of addition / harvest group after connection of the autoclaved valve
- Connect TPE tubing from bag and valve by welding via e.g. BioWelder®

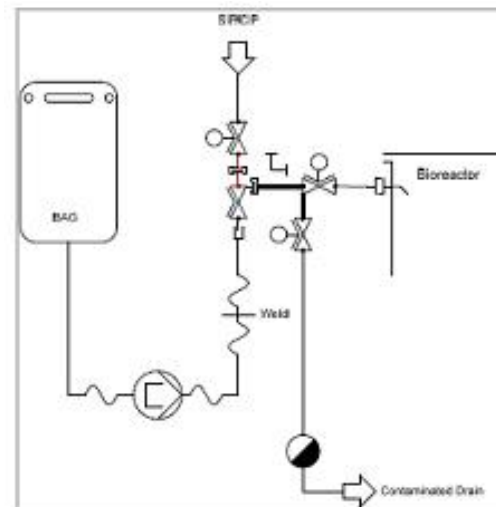

BIOSTAT® D-DCU

Your Fast Track to a Complete Upstream Solution
from Media Prep to Cell Harvest

Flexel®

Liquid storage bag

BioSealer®

TPE tube sealer

Sartoclear®

Depth filter

FlexAct®

MP: Media Preparation

CH: Cell Harvest

BioWelder®

TPE tube welder

Flexboy®

Media storage bag

Sartopore® 2

Liquid Filter

TAKEONE®

Aseptic single-use Sampling

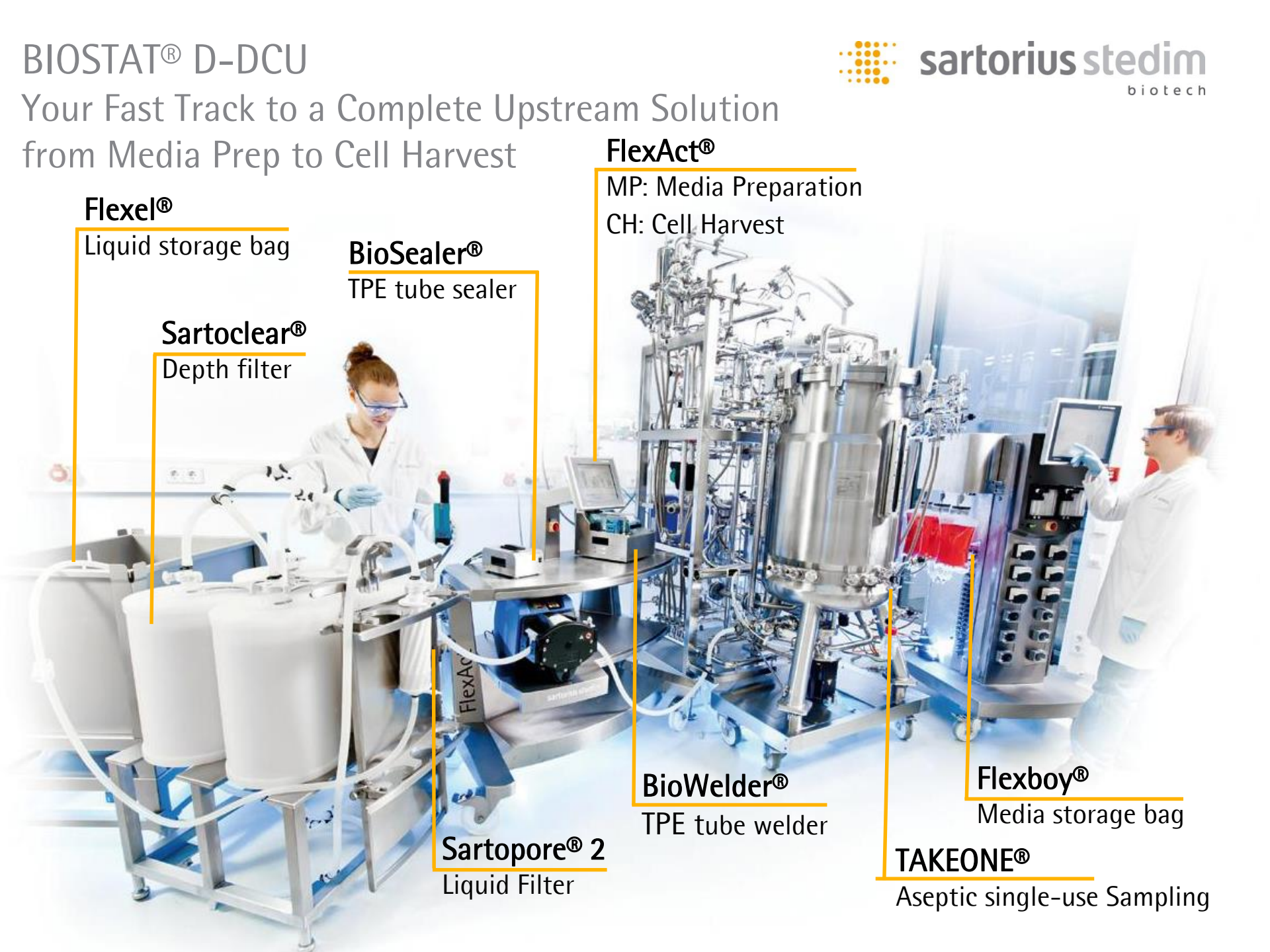



Thank you for your attention